



## Authorized Hibon Distributor, Warranty, Service & Repair Facility

Visit us online: [www.fraserwoods.ca](http://www.fraserwoods.ca)

### VTB 820.MA Air Injection Blower

Call **1-780-962-1827** for technical, application and sales support.

The VTB 820.MA Vacuum Blower is self cooling, requiring no vacuum relief valve and is designed for continuous industrial use, 24 hours a day. The self-cooling design enables warm gasses to be handled and eliminates or reduces the need for precooling.

The Hibon VTB series are the only dry positive displacement blowers capable of attaining 28" Hg vacuum/93% vacuum. The design provides for oil free and water free operation. Readily adaptable as a replacement unit, VTB series blowers are available in various configurations, e.g. high or low shaft, counter or clockwise rotation.

- Heavy-duty bearing holders on thrust end for more axial load capability.
- Helical gears located on the drive side for more input torque capability.
- Five bearing with drive shaft roller bearing suitable for V-belt and direct drives.
- Large oil sumps for improved bearing lubrication.
- Shafts are keyed to the lobes. High tensile steel provides superior resistance and minimum flexion.
- Trilobes for smoother operation with less vibration and pulsating noise.
- Piston ring seals for lifetime reliability.
- Oil thrower and oil passages for good bearing lubrication and long life.

### Specifications

Max Vacuum	27" Hg
CFM	1400
Maximum RPM	3400
Minimum RPM	2200
Max Outlet (discharge) Pressure	Atmospheric Pressure + Max Differential Pressure
Max Inlet Pressure	Atmospheric Pressure
Max Outlet Vacuum	Atmospheric Pressure
Max Inlet Vacuum	101 mbar, 1.01 x 10 <sup>4</sup> Pa, 75.75 Torr
Max Differential Pressure (inlet-outlet)	1200 mbar 1.2 x 10 <sup>5</sup> Pa, 900 Torr
Shaft Dia.	1.65" (42mm)
Drive End Lubrication	Hibon Lube
Opposite Drive End Lubrication	Hibon Lube
Drive End Cover – Horiz	1.1 Litres (0.29 US gal)
Drive End Cover – Vert	1.0 Litres (0.26 US gal)
Opp. Drive End Cover – Horiz	0.9 Litres (0.24 US gal)
Opp. Drive End Cover - Vert	1.7 Litres (0.45 US gal)
Bare Unit Weight	507 Lbs (230 Kg)
Container	Wood Skid
Shipping Weight on Skid	557 lbs
Shipping Options	Ground Freight, Air or Sea

BLOWER	SPEED RPM	VACUUM PERFORMANCE															
		6" Hg		9" Hg		12" Hg		15" Hg		18" Hg		21" Hg		24" Hg		27" Hg	
		CFM	BHP	CFM	BHP	CFM	BHP	CFM	BHP	CFM	BHP	CFM	BHP	CFM	BHP	CFM	BHP
<b>VTB 820.MA</b> (1400 CFM*) *Free Air Displacement at Maximum Speed	3400	1272	21	1235	29	1197	37	1153	47	1091	56	984	64	723	73	126	82
	3200	1190	20	1153	27	1115	35	1071	44	1009	52	902	60	641	68	44	77
	3000	1108	18	1071	26	1033	33	989	42	927	49	820	57	559	64	∅	72
	2800	1027	17	989	24	951	31	907	39	845	46	738	53	478	60	-	-
	2600	945	16	908	22	869	29	825	36	763	43	656	49	396	56	-	-
	2200	781	13	744	19	705	24	661	30	599	36	492	41	232	68	-	-

NOTES: Performance data is based on an inlet temperature of 68°F at sea level, (∅) Inlet blanked off (data provided for information only), (-) No throughput/vacuum level unattainable

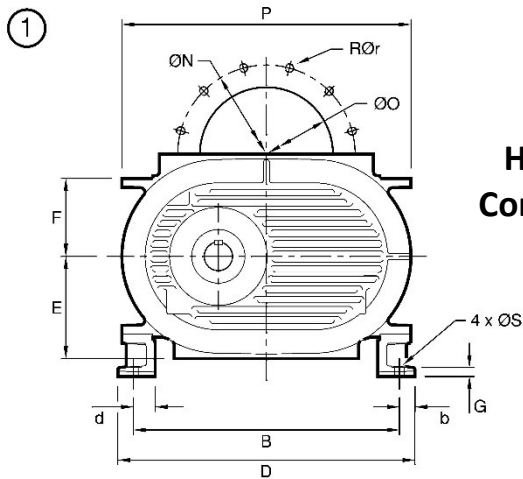

**Horizontal Configuration**

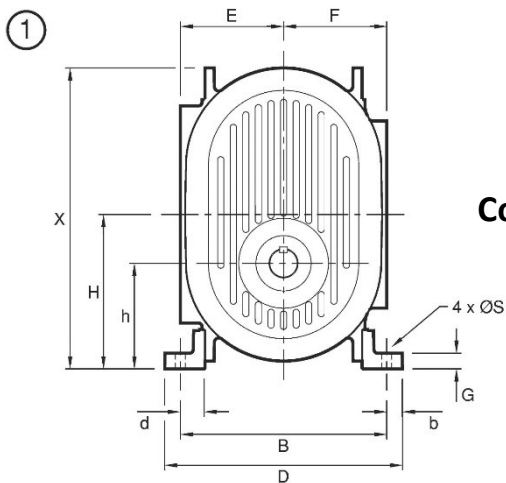
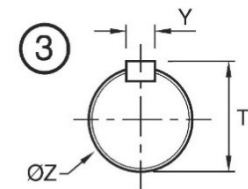
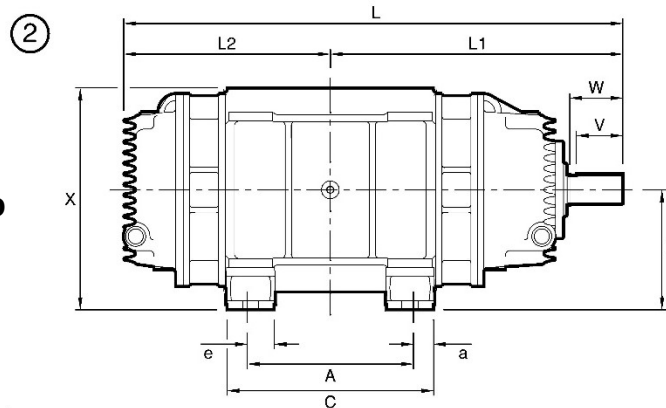

**Vertical Configuration**

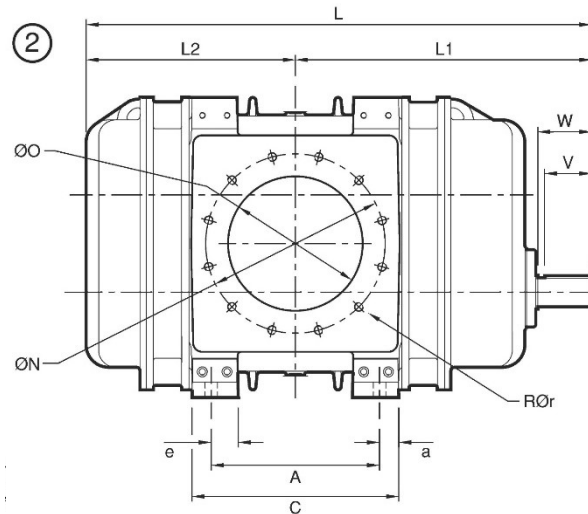

Dimensions mm (inch)				
A	a	B	b	C
300 (11.81)	30 (1.18)	370 (14.57)	24 (0.94)	360 (14.17)
D	d	E	e	F
418 (16.46)	54 (2.13)	155 (6.1)	360 (14.17)	155 (6.1)
G	H	h	L	L1
10 (0.39)	217.5 (8.56)	150 (5.90)	778 (30.63)	430 (16.93)
L2	N	O	P	RØr
348 (13.7)	240 (9.49)	150 (5.9)	420 (16.53)	4 [M20]
S	T	V	W	X
18 (0.71)	45 (1.77)	70 (2.75)	80 (3.15)	420 (16.53)
Y	Z*			
12 (0.47)	42 (1.65)			

Notes: \*Fitting tolerance range: M6

VTB 820.MA Discharge (Outlet)/Injection Port Dimensions: mm (inch)

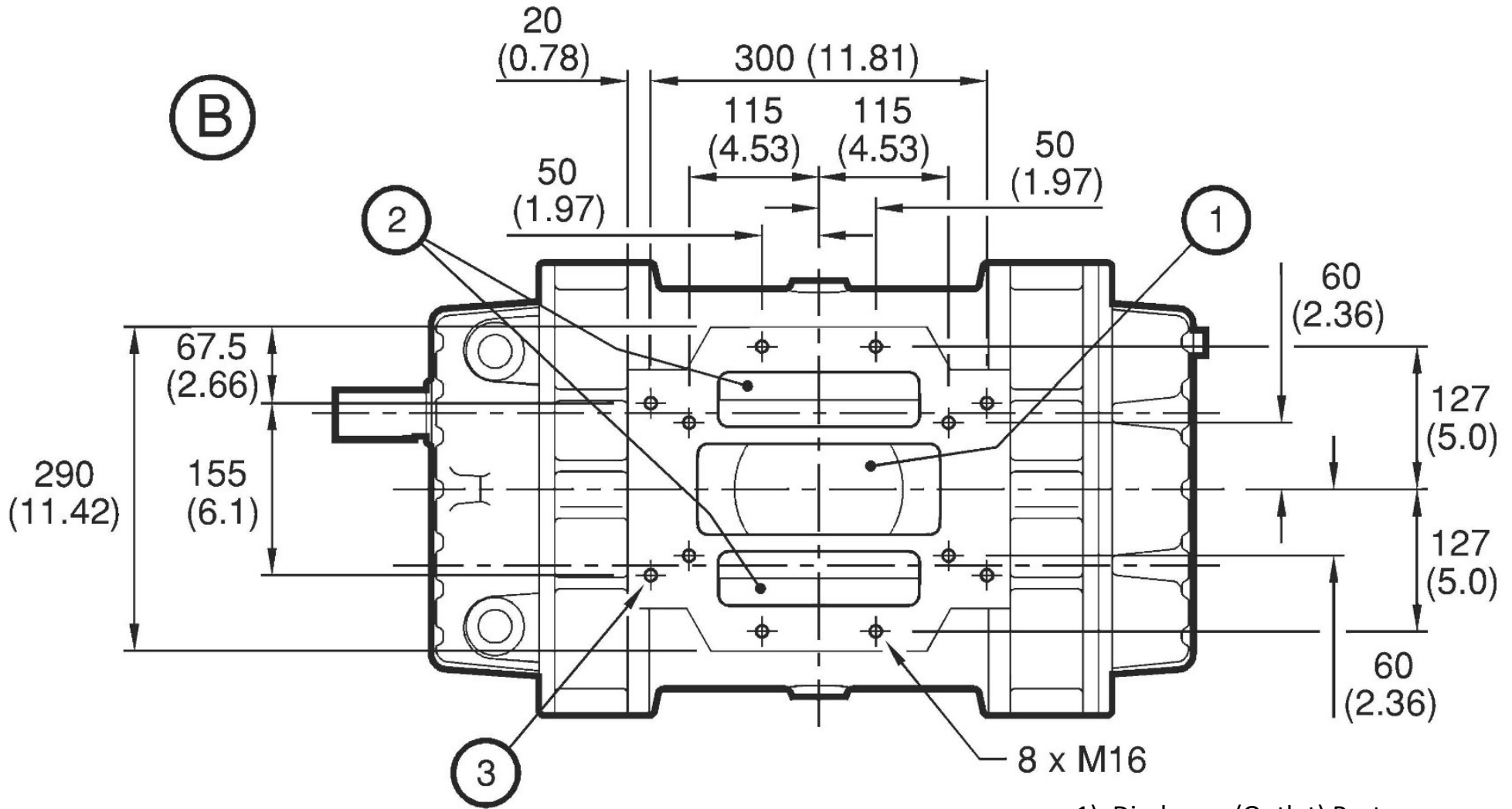

- 1) Discharge (Outlet) Port
- 2) Injection Ports (2 Off)
- 3) Blower Fixing Holes (4 Off, M16)

VTB 820.MA Horizontal Blower Fixing Hole (Inlet Side): mm (inch)

2) Blower Fixing Holes (4 Off): M16

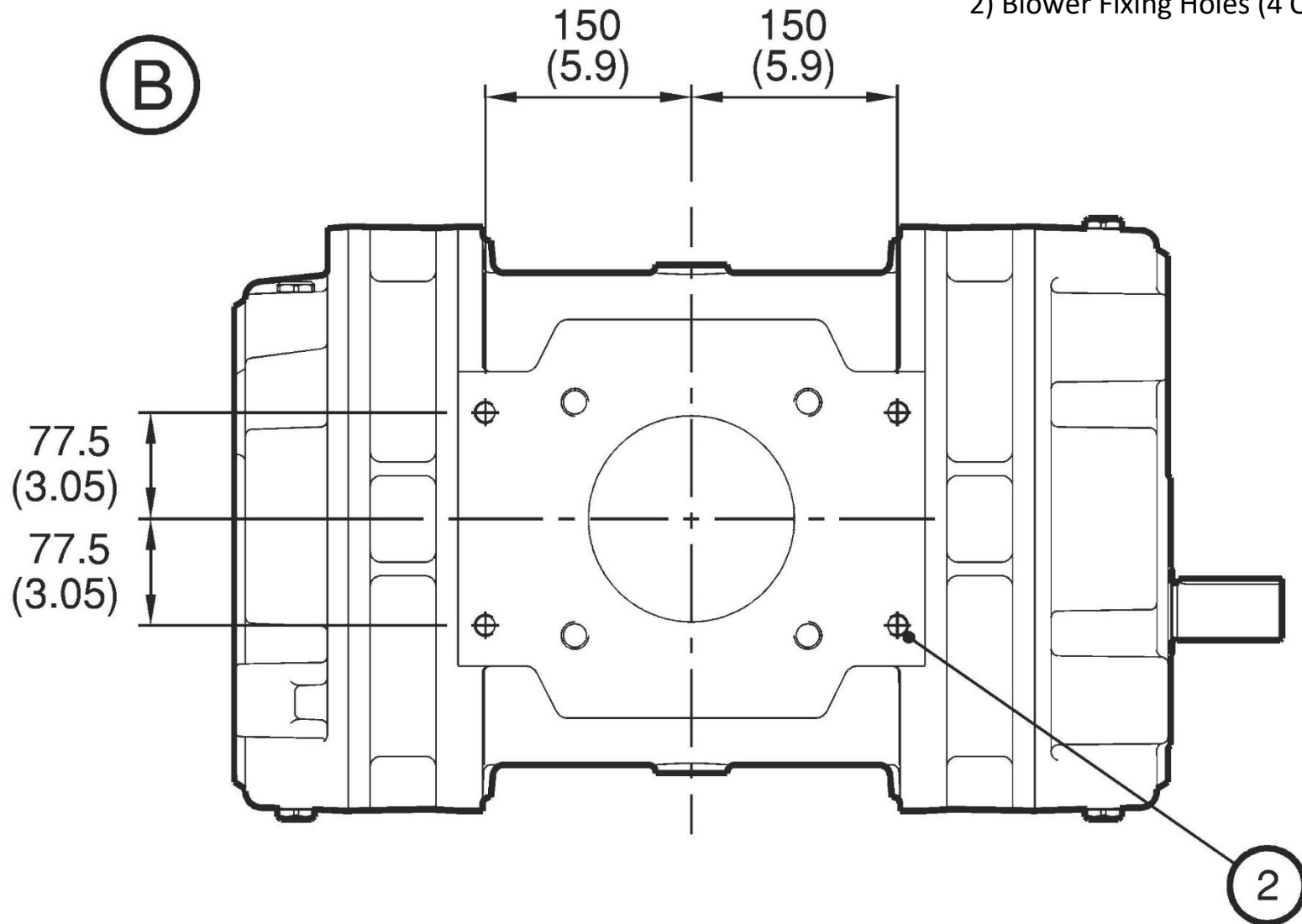

## VTB/SIAV Air Injection Blower (SIAV Shown)

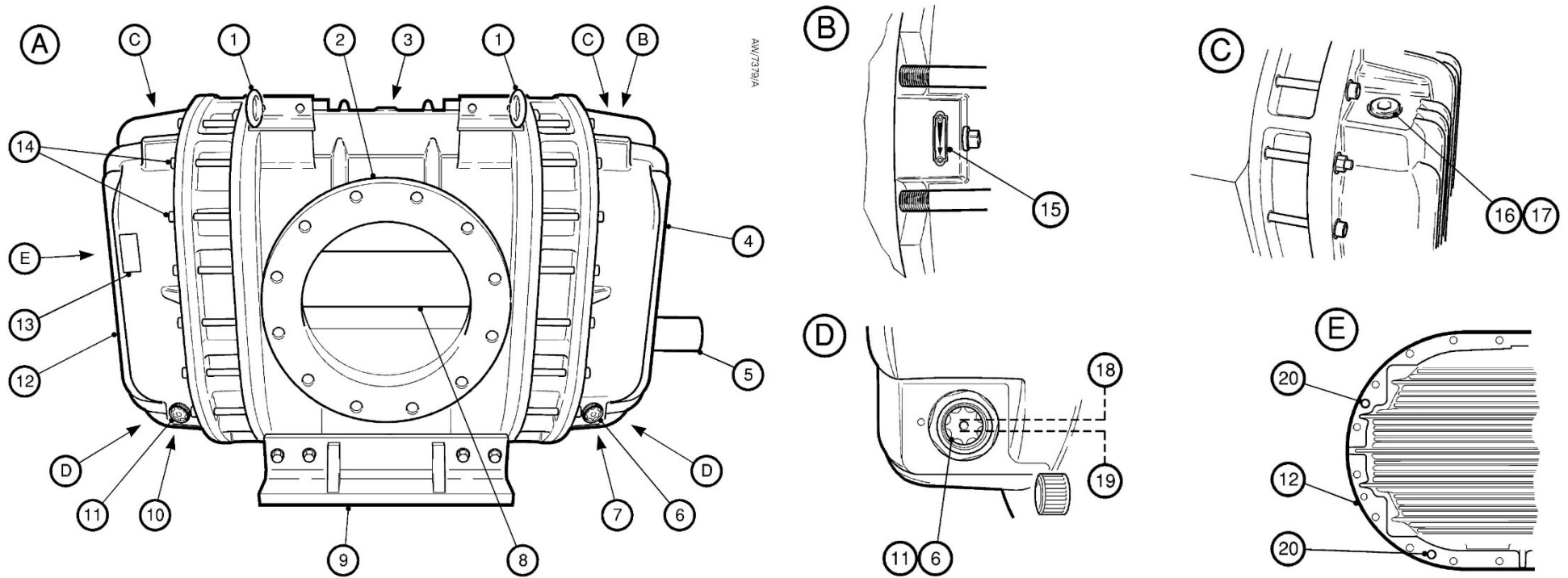

- 1) Lifting Blots
- 2) Inlet
- 3) Discharge (Outlet)/Injection Ports (behind blower)
- 4) Drive End Cover
- 5) Drive Shaft
- 6) Oil-Level Sight-Glass (non-drive end cover)
- 7) Drive End Oil Drain Plug
- 8) Rotors
- 9) Mounting Plates (1 each side)
- 10) Non-Drive End Oil Drain Plug

- 11) Oil-Level Sight-Glass (non-drive end cover)
- 12) Non-Drive End Cover
- 13) Identification and Rating Plate
- 14) Head Plate Bolts
- 15) Direction of Rotation Arrow
- 16) Oil Filler Plug (drive end cover)
- 17) Oil Filler Plug (non-drive end cover)
- 18) Maximum Oil Level
- 19) Minimum Oil Level
- 20) Earth (Ground) Studs

# VTB 820.MA AIR INJECTION BLOWER

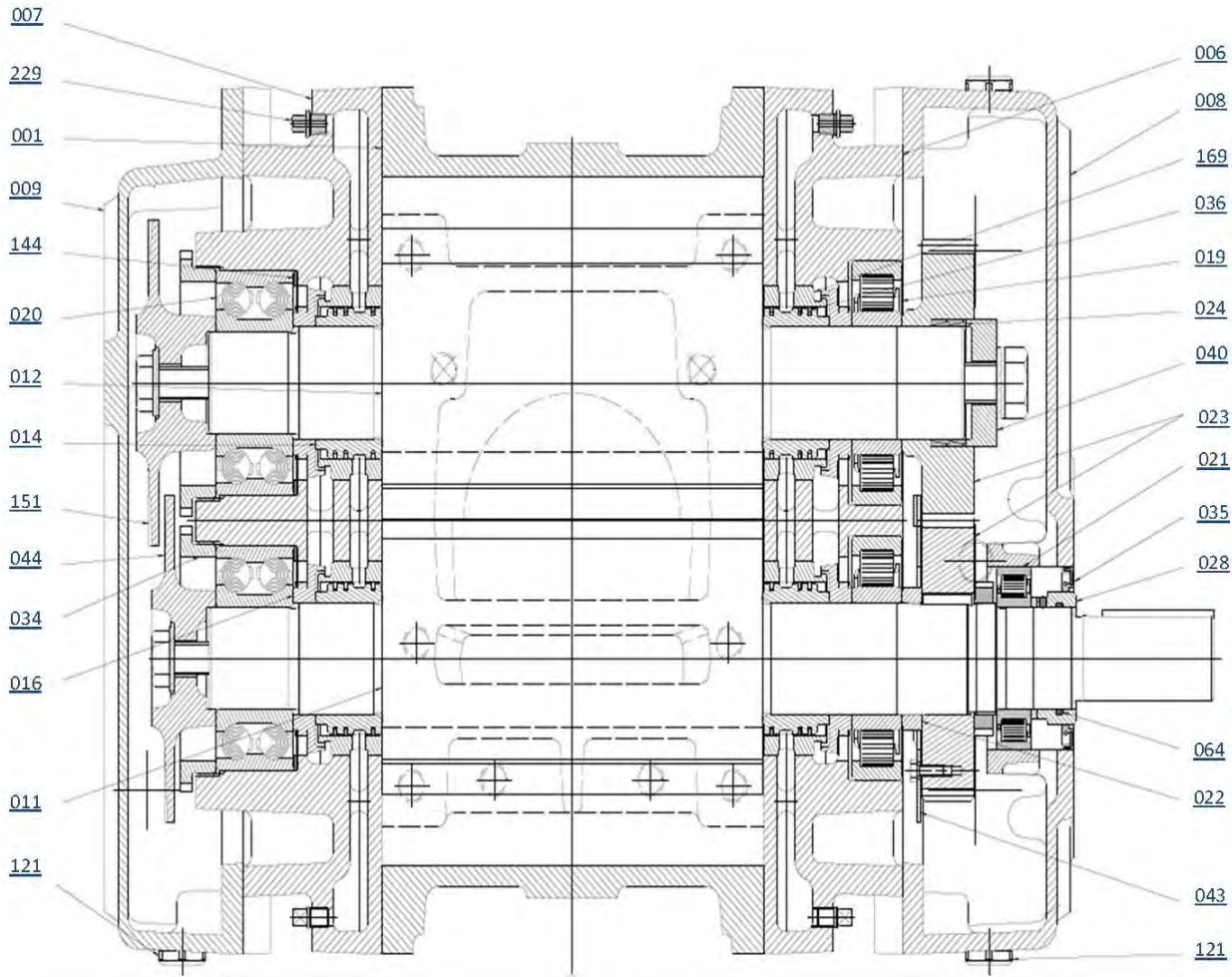

ITEM	QTY	DESCRIPTION
001	1	Casing VTB 820
008	1	Oil Casing, Drive Side
009	1	Oil Casing, Opposite Side
043	1	Oil Splasher, Drive Side
044	1	Oil Splasher, Opposite Side, Drive Gear
151	1	Oil Splasher, Opposite Side, Driven Gear
	1	Shaft Outlet Cover
	2	Oil Drain Plug Dia. (1/2")
	1	Seal DIA. 21 X 26 EP
	1	Manifold Gasket
KIT		Set of Gears
KIT		Set of Rings
KIT		Set of Sealing Parts
KIT		Set of Bearings
KIT		Set of Ring Holders
KIT		Set of Complimentary Rings
KIT		Set of Rotors
KIT		End Plate Kit, Gear Side
KIT		End Plate Kit, Opposite Gear Side
KIT		Set of Oil Sight Glasses

# Performance m<sup>3</sup>/h

Performance data is based on an inlet temperature of 20°C at sea level.

BO = Blanked off

Blower	Speed T/mn	20% Vacuum		30% Vacuum		40% Vacuum		50% Vacuum		60% Vacuum		70% Vacuum		80% Vacuum		90% Vacuum		93% Vacuum	
		m <sup>3</sup> /h	KW	m <sup>3</sup> /h	kW	m <sup>3</sup> /h	KW	m <sup>3</sup> /h	KW	m <sup>3</sup> /h	KW	m <sup>3</sup> /h	KW	m <sup>3</sup> /h	KW	m <sup>3</sup> /h	KW	m <sup>3</sup> /h	KW
VTB 810 (1500 m <sup>3</sup> /h*)	3300	1344	11	1307	15	1271	19	1223	23	1125	27	1047	31	836	35	175	39		
	3000	1211	10	1174	13	1133	17	1089	21	1026	25	917	28	651	31	42	35		
	2700	1077	9	1040	13	999	16	957	19	892	22	783	25	518	28	BO			
	2400	945	8	907	11	866	13	822	16	759	19	649	22	384	25				
VTB 820 (2400 m <sup>3</sup> /h*)	3400	2161	16	2098	22	2034	28	1959	35	1854	42	1672	48	1228	54	214	61		
	3200	2022	15	1959	20	1894	26	1820	33	1714	39	1533	45	1089	51	75	57		
	3000	1882	13	1820	19	1755	25	1680	31	1575	37	1393	43	950	48	BO	54		
	2800	1745	13	1680	18	1616	23	1541	29	1436	34	1254	40	812	45				
	2600	1606	12	1543	16	1476	22	1402	27	1296	32	1115	37	673	42				
	2200	1327	10	1264	14	1198	18	1123	22	1018	27	836	31	394	35				
SIAV 822 (4500 m <sup>3</sup> /h*)	3000	4025	28	3996	39	3930	50	3855	62	3748	73	3565	85	3119	98	2097	110	BO	114
	2750	3704	25	3641	36	3575	46	3534	57	3393	67	3209	78	2764	89	1741	101		
	2450	3277	22	3215	31	3148	41	3073	51	2966	60	2783	69	2338	80	1315	89		
	2150	2851	19	2788	28	2722	36	2647	44	2540	52	2357	61	1911	70	889	78		
	1850	2424	17	2362	24	2295	31	2221	38	2114	45	1930	53	1485	60	460	68		
	1600	2069	15	2005	21	1939	27	1864	33	1758	39	1575	45	1162	52	105	58		
SIAV 840 (6500 m <sup>3</sup> /h*)	2600	6077	42	5964	60	5843	78	5738	89	5554	107	5238	125	4472	143	2712	163	BO	168
	2340	5469	37	5367	54	5258	69	5163	81	4998	96	4715	113	4025	128	2440	146		
	2165	4995	34	4881	49	4761	64	4654	75	4468	89	4151	104	3379	121	1609	139		
	1850	4186	30	4062	43	3931	55	3816	63	3617	76	3272	89	2438	101	BO	114		
	1410	3082	22	2953	32	2817	42	2698	48	2491	58	2136	68	1271	77				
	800	1616	13	1502	19	1383	24	1276	28	1092	33	776	39	10	44				
SIAV 8702 (9000 m <sup>3</sup> /h*)	2000	8371	55	8262	78	8148	101	8021	128	7838	151	7521	174	6755	199	4995	224	BO	232
	1800	7499	50	7391	70	7277	91	7148	115	6964	136	6648	157	5882	180	4123	202		
	1600	6626	45	6517	63	6404	81	6274	102	6091	121	5777	139	5010	160	3250	180		
	1400	5755	39	5644	54	5530	71	5403	89	5219	106	4903	122	4137	139	2379	157		
	1200	4881	34	4773	47	4659	60	4530	77	4346	90	4030	104	3264	119	1505	135		
	800	3136	22	3026	31	2912	40	2785	51	2601	60	2285	70	1519	80	BO	89		
SIAV 8902 (11160 m <sup>3</sup> /h*)	2000	10792	70	10112	96	9879	124	9817	164	9606	185	9205	224	8268	256	6113	289	BO	299
	1800	9190	61	9070	88	8861	112	8760	141	8538	165	8147	192	7208	219	5052	247		
	1600	8121	54	8015	77	7830	98	7689	125	7458	144	7079	171	6139	196	3983	219		
	1400	7053	48	6961	68	6801	86	6654	109	6394	124	6008	149	5070	171	2915	192		
	1200	5982	40	5904	58	5768	73	5551	94	5431	109	5204	129	4000	147	1844	165		
	800	3843	27	3793	39	3706	48	3413	62	3137	72	2800	86	1861	98	BO	110		

\*Free air displacement at maximum speed.



# PERFORMANCE CURVES – VACUUM

## MODEL : VTB 820 TRI-LOBES

<b>SUCTION CONDITIONS</b> Gas : AIR Density : .075 lbs/Ft Maximum vacuum : 27" Hg Minimum speed : 710 RPM Maximum speed : 3600 RPM Barometric p. abs. : 29.92 Hg"		Qv = Inlet volume CFM Po = Absorbed power Hp Ve = Volume displacement Δp = Differential pressure Hg" N = Blower speed RPM Blower with manifold HIBON	Gear size : 5.3" 135 mm Displacement : 0.405 cfr 11.45 L/rev.
REV : 0	96.06.03	By : C.B.	

