

Instruction Manual

VTBH/V and SIAH/V Air Injection Blowers



Authorized Hibon Distributor, Service & Repair Facility

120 – 10293 276 ST, Acheson, Alberta, Canada T7X 6A5

T: 780.962.1827 F: 780.962.1830 E: sales@fraserwoods.ca

www.fraserwoods.ca

CONTENTS

Section		Page
1	INTRODUCTION	1
1.1	Scope and definitions	1
1.2	Description	1
1.2.1	Introduction	1
1.2.2	Standard/ATEX compliant blowers	1
1.2.3	Principle of operation	2
1.2.4	ATEX certification and compliance (ATEX compliant blowers only)	2
1.3	ATEX Directive (94/9/EC): Europe only (ATEX compliant blowers only)	3
1.3.1	Introduction	3
1.3.2	Temperature classification	3
1.3.3	Normal operation	6
1.3.4	Abnormal operation	6
1.4	Applications	6
2	TECHNICAL DATA	7
2.1	Operating and storage conditions	7
2.2	Performance	7
2.3	Mechanical data	13
2.4	Lubrication data	13
2.5	Noise and vibration data	13
2.6	Connections	14
2.7	Materials of construction	14
2.8	Item Numbers	16
3	INSTALLATION	25
3.1	ATEX compliant blower installation requirements	25
3.2	Installation safety	25
3.3	System design	25
3.3.1	General requirements	25
3.3.2	System safety	26
3.4	Unpack and inspect	26
3.5	Locate the blower	27
3.5.1	VTB810H and VTB820H blowers	27
3.5.2	Other blowers	27
3.6	Connect the blower into your system	28
3.7	Fill the blower with oil	28
3.8	Connect the blower to earth (ground) (ATEX compliant blowers only)	28
3.9	Fit the drive/transmission	29
3.10	Check the direction of rotation	30

CONTENTS (CONTINUED)

Section		Page
4	OPERATION	31
4.1	General operational safety	31
4.2	Start-up	31
4.2.1	Pressure operation	31
4.2.2	Vacuum operation	34
4.3	Shut-down	34
4.3.1	Pressure operation	34
4.3.2	Vacuum operation	34
5	MAINTENANCE	35
5.1	Safety information	35
5.2	Maintenance plan	35
5.3	Inspect the oil-level sight-glasses	36
5.4	Check the oil levels	36
5.4.1	Drive end cover	36
5.4.2	Non-drive end cover	37
5.5	Inspect the system installation	37
5.6	Change the oil	38
5.6.1	Drive end cover	38
5.6.2	Non-drive end cover	38
5.7	Overhaul the blower	38
5.8	Fault finding	38
6	STORAGE AND DISPOSAL	41
6.1	Storage	41
6.1.1	Preparation	41
6.1.2	Long-term storage	41
6.2	Disposal	42
7	SERVICE, SPARES AND ACCESSORIES	43
7.1	Introduction	43
7.2	Service	43
7.3	Spares and accessories	43
	RETURN OF Ingersoll Rand EQUIPMENT	

ILLUSTRATIONS

Figure		Page
1	Principle of operation	2
2	The VTBH/V and SIAH/V blowers	5
3	Ordering configurations	17
4	VTBH and SIAH blower dimensions	19
5	VTBV and SIAV blower dimensions	21
6	Discharge (outlet)/injection ports dimensions: mm (inch)	22
7	VTB810H and VTB820H blower fixing hole (inlet side) dimensions: mm (inch)	24
8	Recommended system configuration: pressure operation	32
9	Recommended system configuration: vacuum operation	33

TABLES

Table		Page
1	ATEX rating notation	3
2	Operating and storage conditions	4
3	Operating and storage conditions	7
4	Performance data: VTB810H/V and VTB820H/V	7
5	Performance data: SIAH/V822	7
6	Performance data: SIAH/V840, SIAH/V8702 and SIAH/V 8902	7
7	Vacuum performance data	8
8	Mechanical data	13
9	Lubrication data	13
10	Noise and vibration data	13
11	Connections data	14
12	Construction materials data	14
13	Item Numbers	16
14	Checklist of items	27
15	Maximum drive shaft loadings	29
16	Maintenance plan	36
17	Fault finding	39
18	Suitable protective oils	41
19	Spares and accessories	44

I INTRODUCTION

I.1 Scope and definitions

This manual provides installation, operation and maintenance instructions for the Ingersoll Rand VTBH/V and SIAH/V Air Injection Blowers, abbreviated to "VTBH/V and "SIAH/V blowers", or "blowers" in the remainder of this manual. You must use the blower as specified in this manual.

Read this manual before you install the blower. Important safety information is highlighted as WARNING and CAUTION instructions; you must obey these instructions. The use of WARNINGS and CAUTIONS is defined below.

	<p>WARNING</p> <p>Warnings are given where failure to observe the instruction could result in injury or death to people.</p>
--	---

<p>CAUTION</p> <p>Cautions are given where failure to observe the instruction could result in damage to the equipment, associated equipment and process.</p>

The units used throughout this manual conform to the SI international system of units of measurement.

The identification and rating plate (Figure 2, item 13) provides specific details about the blower.

The following warning and other symbols are on the blower:

	Warning - refer to accompanying documentation.
---	--

	Warning - hot surfaces.
---	-------------------------

	Protective earth (ground).
---	----------------------------

I.2 Description

I.2.1 Introduction

Refer to Figure 2. The VTBH/V and SIAH/V are positive displacement blowers, which incorporate two three-lobe rotors (8). One of the rotors is driven by the drive shaft (5). The other rotor is maintained in the correct phase relation by timing gears. The timing gears and the bearings on the rotors and drive shaft are lubricated by oil in the drive end cover (4) and non-drive end cover (12).

The blowers are supplied in 'bareshaft' form. You must connect your own coupling or belt drive system (see Section 3.9) to the drive shaft (5) in order to operate the blower.

The blowers are cooled by fresh air injection: see Section 1.2.3 for more information.

All of the VTBH/V and SIAH/V blowers are suitable for pressure or vacuum operation: see Figures Figure 8 and Figure 9 - and Section 4 for more information.

The blowers are available in different configurations, and in two different versions:

- 'H' version blowers, which are installed horizontally.
- 'V' version blowers, which are installed vertically.

Refer to Section 2.8 and Figure 3 for the different blower configurations/versions.

I.2.2 Standard/ATEX compliant blowers

The following models of blowers are available:

- Standard blowers: these are **only** suitable for pumping/compressing ambient air, and non-flammable gases, gas mixtures and dusts.

- ATEX Category 2 compliant blowers: these comply with the European ATEX Directive, and are suitable for pumping/compressing non-flammable or flammable gases, gas mixtures and dusts: see Sections 1.2.4 and 1.3 for more information.

1.2.3 Principle of operation

Refer to Figure I. During operation, the inlet gas stream (1) to be pumped/compressed enters the blower at the inlet.

As the two contra-rotating rotors turn (as in the sequence shown in details A, B and C):

- The inlet gas is trapped in the chambers (4) which form between the rotors and the blower-body, and is eventually forced out of the blower at the discharge (outlet) (3).
- Ambient injection air (2) is drawn into the blower (through the injection ports: see Figure 6). This air cools the blower during operation.

1.2.4 ATEX certification and compliance (ATEX compliant blowers only)

All of the ATEX Category 2 compliant blowers have been specifically developed to meet the requirement for a blower capable of pumping/compressing a flammable atmosphere with an internal area classification of Zone 1, without the need for protective devices such as flame arrestors.

The blowers have also been developed to operate in an external flammable environment with an area classification of Zone 1.

The blowers are certified (in accordance with 94/9/EC) as Category 2 equipment under the European ATEX Directive; for this certification to be valid, the blowers **must** be installed and operated exactly as specified in this manual.

The blowers have been designed using the principle of constructional safety, which ensures that potential ignition sources are eliminated, even in the event of frequently occurring disturbances and malfunctions.

The blowers are suitable for pumping/compressing a wide range of flammable and non-flammable gases and vapours, subject to the restrictions specified in Section 1.3.4.

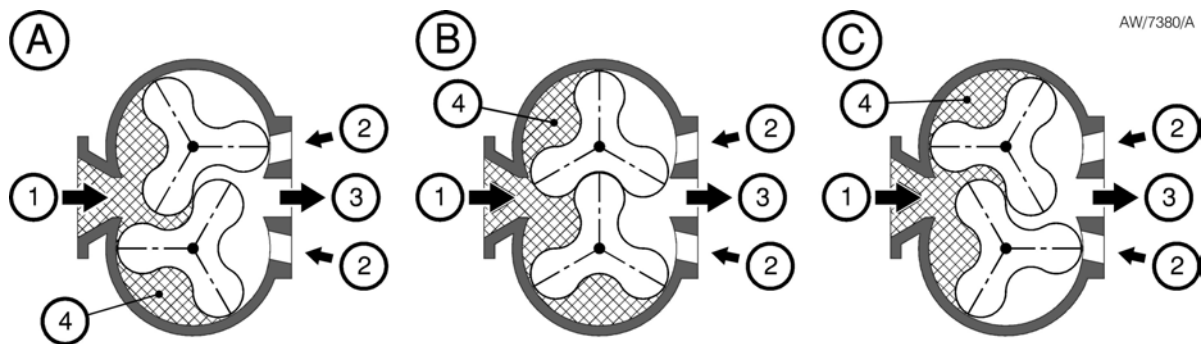

1. Inlet gas stream
2. Injection air
3. Discharge (outlet) gas stream
4. Chambers

Figure I - Principle of operation

**1.3 ATEX Directive (94/9/EC): Europe only
(ATEX compliant blowers only)**

1.3.1 Introduction

The ATEX Category 2 compliant blowers must be incorporated into a larger system on which the internal atmosphere has an area classification of Zone I. Such systems will be certified in accordance with the above Directive, and must be identified by an ATEX system rating label.

For certification to be valid, the blowers **must** be installed exactly as specified in this manual.

The blowers are fitted with an ATEX rating label which contains the following information:



II 2 G/D c, IIB T3 160°C X internal
II 2 G/D c, IIB T3 160°C X external

The notations used in the ratings on the label are as shown in Table 1.

1.3.2 Temperature classification



WARNING

ATEX Category 2 compliant blowers must be operated in accordance with the requirements of the procedures given in Section 4, to ensure that the temperature classification is not exceeded.

The temperature classification applied to the ATEX Category 2 compliant blowers relates to the auto-ignition temperature of flammable materials that can be pumped/compressed, or which can exist in the external atmosphere.

The temperature classification of the ATEX compliant blowers is T3 160°C (320 °F) for internal and external gas/dust atmospheres. For external dust atmospheres, you must ensure that a suitable safety margin is applied to the use of the blower, based on the nature/composition of the dust and the dust layer thickness.

Note that ATEX compliant blowers must not be operated (in pressure operation) with a pressure differential higher than those specified in Tables 3 to 5, otherwise the temperature classification will be exceeded.

Refer to Section 2 of this manual for the necessary blower operating conditions.

	Specifies that the blower can be used in a potentially explosive atmosphere.
II	Equipment group II (non-mining)
2	Equipment category 2
G/D	Suitable for potentially explosive internal gas/ dust atmospheres
c	Complies with ‘constructional safety’ protection strategy
IIB	Suitable to pump gas group IIB
T3 160°C	Gas/dust auto-ignition temperature: see Section 1.3.2.
X	Identifies that specific operating requirements are required to ensure compliance with the temperature classification: refer to Section 1.3.2.

Table 1 - ATEX rating notation

1. Lifting bolts
2. Inlet
3. Discharge (outlet)/injection ports (behind blower)
4. Drive end cover
5. Drive shaft
6. Oil-level sight-glass (drive end cover)
7. Drive end oil drain plug
8. Rotors
9. Mounting plates (1 each side)
10. Non-drive end oil drain plug
11. Oil-level sight-glass (non-drive end cover)
12. Non-drive end cover
13. Identification and rating plate
14. Head plate bolts
15. Direction of rotation arrow
16. Oil filler plug (drive end cover)
17. Oil filler plug (non-drive end cover)
18. Maximum oil level
19. Minimum oil level
20. Earth (ground) studs

Figure 2 - The VTBH/V and SIAH/V blowers: key

VTBH/V and SIAH/V Air Injection Blowers

AM/7379/A

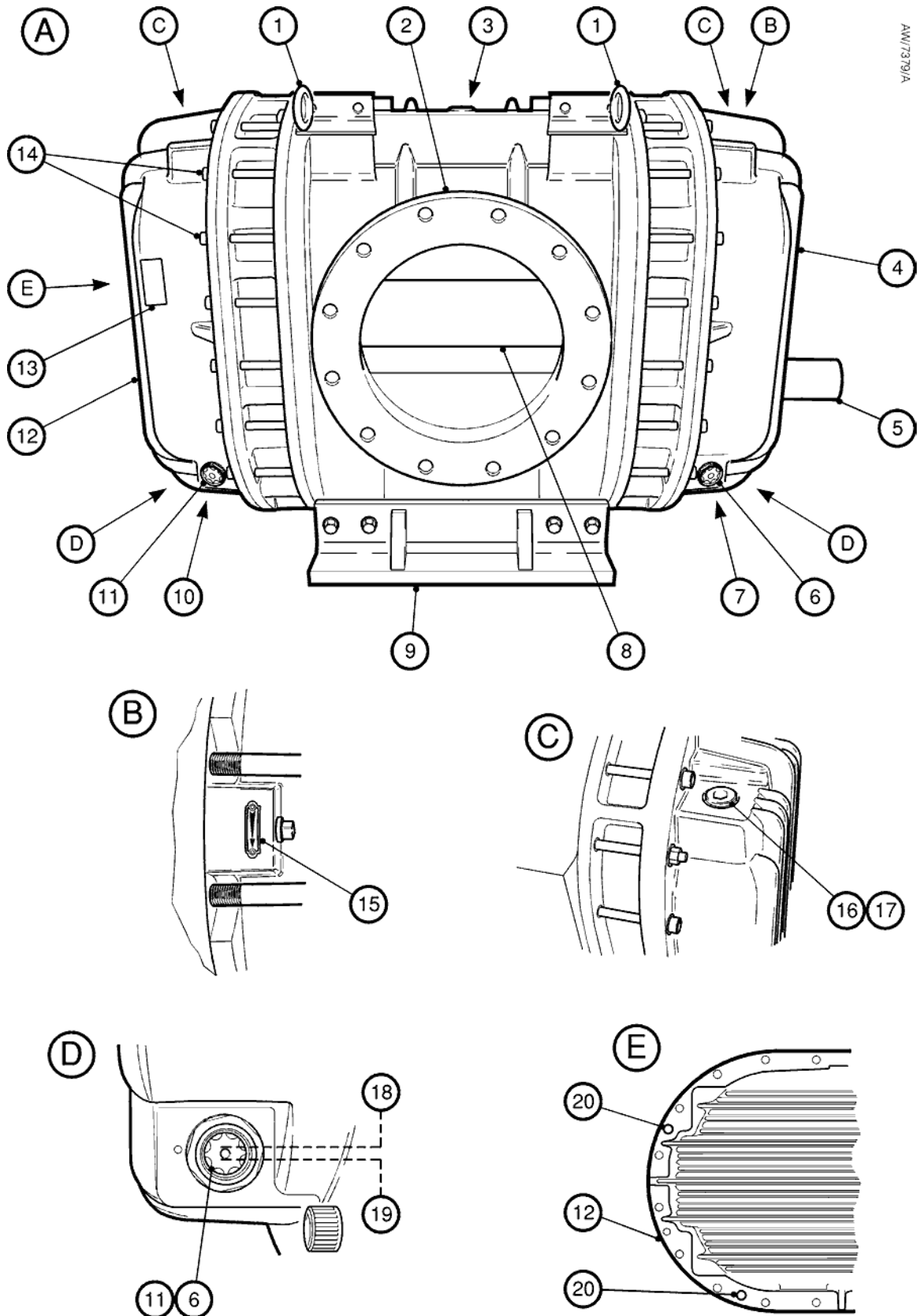



Figure 2 - The VTBH/V and SIAH/V blowers

1.3.3 Normal operation

	<p style="text-align: center;">WARNING</p> <p>The ATEX Category 2 compliant blowers rely on the principle of constructional safety to pump/compress flammable gases and vapours safely. To conform with constructional safety requirements, it is your responsibility to ensure that particles larger than 25 µm cannot enter the blower at any time.</p>
---	--

The ATEX Category 2 compliant blowers rely on the blower's constructional safety for the safe pumping/compressing of flammable materials. In normal operation, as defined by this manual, the blower is safe for the pumping/compressing of flammable materials where there is no risk that particles (larger than 25 mm) could enter the blower at any time, and so cause a potential ignition hazard.

Where there is no such risk, the blower can be used to pump/compress flammable materials from gas group IIB, within the normal parameters as defined in this manual.

The materials of construction of the blowers are specified in Section 2.7. Before you use the blower, you must ensure that these materials are compatible with the gases and vapours which may exist in the external atmosphere.

1.3.4 Abnormal operation

	<p style="text-align: center;">WARNING</p> <p>Misuse of the ATEX Category 2 compliant blowers as described below is strictly prohibited</p>
---	--

- Pumping/compressing gases or gas mixtures with temperatures greater than the system temperature classification (see Section 1.3.2).
- Pumping/compressing gases or gas mixtures with auto-ignition temperatures lower than the system temperature classification (see Section 1.3.2).
- Pumping/compressing hydrocarbon oxides.
- Pumping/compressing pyrophoric gases.
- Use with oxygen enriched atmospheres.
- Use of the blower in ambient conditions other than those specified in Section 2.1.

1.4 Applications

The VTBH/V and SIAH/V blowers are suitable for use in a wide range of applications. You must ensure that your blower is suitable for your application.

If you have any doubts as to the suitability of the blower for your application, contact your supplier or Ingersoll Rand for advice.

2 TECHNICAL DATA

2.1 Operating and storage conditions

Ambient operating temperature range	-20 to 40 °C, -4 to 104 °F
Ambient storage temperature range	-20 to 80 °C, -4 to 176 °F
Maximum ambient operating humidity	90%
Maximum operating altitude	3000 m, 9842 ft

Table 2 - Operating and storage conditions

2.2 Performance

Maximum outlet (discharge) pressure	Atmospheric pressure + maximum differential pressure
Maximum inlet pressure	Atmospheric pressure
Maximum outlet vacuum	Atmospheric pressure
Maximum inlet vacuum	101 mbar, 1.01×10^4 Pa, 75.75 Torr
Maximum differential pressure (inlet-outlet)	1200 mbar, 1.2×10^5 Pa, 900 Torr
Vacuum performance	See Table 6
Rotational speed range	See Table 6
Nominal shaft power (vacuum operation)	See Table 6
Maximum absorbed shaft power (pressure operation)	53.4 kW, 71.6 h.p. (VTB810H/V) 82.5 kW, 110.6 h.p. (VTB820H/V)

Table 3 - Performance data: VTB810H/V and VTB820H/V

Maximum outlet (discharge) pressure	Atmospheric pressure + maximum differential pressure
Maximum inlet pressure	Atmospheric pressure
Maximum outlet vacuum	Atmospheric pressure
Maximum inlet vacuum	101 mbar, 1.01×10^4 Pa, 75.75 Torr
Maximum differential pressure (inlet-outlet)	900 mbar, 9×10^4 Pa, 675 Torr
Vacuum performance	See Table 6
Rotational speed range	See Table 6
Nominal shaft power (vacuum operation)	See Table 6
Maximum absorbed shaft power (pressure operation)	120.2 kW, 161.2 h.p.

Table 4 - Performance data: SIAH/V822

Maximum outlet (discharge) pressure	Atmospheric pressure + maximum differential pressure
Maximum inlet pressure	Atmospheric pressure
Maximum outlet vacuum	Atmospheric pressure
Maximum inlet vacuum	101 mbar, 1.01×10^4 Pa, 75.75 Torr
Maximum differential pressure (inlet-outlet)	950 mbar, 9.5×10^4 Pa, 712.5 Torr
Vacuum performance	See Table 6
Rotational speed range	See Table 6
Nominal shaft power (vacuum operation)	See Table 6
Maximum absorbed shaft power (pressure operation)	180 kW, 241.4 h.p. (SIAH/V840) 244 kW, 327.2 h.p. (SIAH/V8702) 321 kW, 418 h.p. (SIAH/V 8902)

Table 5 - Performance data: SIAH/V840, SIAH/V8702 and SIAH/V 8902

VTBH/V and SIAH/V Air Injection Blowers

Blower (throughput *)	Speed † r min ⁻¹	Vacuum performance #							
		20%				30%			
		m ³ h ⁻¹	kW	cfm	h.p.	m ³ h ⁻¹	kW	cfm	h.p.
VTB810H/V (1500 m ³ h ⁻¹ 883 cfm)	3600	1493	12	879	16.1	1461	16	860	21.4
	3300	1361	11	802	14.7	1329	15	783	20.1
	3000	1227	10	723	13.4	1194	14	703	18.8
	2700	1094	9	644	12.1	1062	12	625	16.1
	2400	960	8	565	10.7	928	11	546	14.7
VTB820H/V (2400 m ³ h ⁻¹ 1414 cfm)	3400	2161	16	1273	21.4	2098	22	1236	29.5
	3200	2022	15	1191	20.1	1959	20	1154	26.8
	3000	1882	14	1108	18.8	1820	19	1072	25.4
	2800	1745	13	1028	17.4	1680	18	989	24.1
	2600	1606	12	946	16.1	1543	17	909	22.8
SIAH/V822 (4500 m ³ h ⁻¹ 2650 cfm)	2200	1327	10	782	13.4	1264	14	744	18.8
	3000	4059	27	2391	36.2	3996	39	2354	52.3
	2750	3704	25	2182	33.5	3641	35	2144	46.9
	2450	3277	22	1930	29.5	3215	32	1894	42.9
	2150	2851	20	1679	26.8	2788	28	1642	37.5
SIAH/V840 (6500 m ³ h ⁻¹ 3828 cfm)	1850	2464	17	1451	22.8	2362	24	1391	32.2
	1600	2069	15	1219	20.1	2005	21	1181	28.1
	2600	6077	42	3579	56.3	5963	60	3512	80.5
	2340	5470	38	3222	50.9	5367	54	3161	72.4
	2165	4996	35	2943	46.9	4881	50	2875	67.0
SIAH/V8702 (9000 m ³ h ⁻¹ 5301 cfm)	1850	4186	30	2465	40.2	4062	43	2392	57.7
	1410	3082	23	1815	30.8	2953	32	1739	42.9
	800	1616	13	471	17.4	1502	18	885	24.1
	2000	8371	55	4927	73.7	8262	78	4866	104.6
	1800	7499	50	4417	67.0	7391	70	4353	93.9
SIAH/V8902 (11160 m ³ h ⁻¹ 6573 cfm)	1600	6626	44	3903	59.0	6517	63	3838	84.5
	1400	5755	39	3390	52.3	5644	55	3324	73.7
	1200	4881	33	2875	44.2	4772	47	2811	63.0
	800	3136	22	471	29.5	3026	31	1782	41.6
	2000	10792	70	6352	95	10112	96	5952	129
	1800	9190	61	5409	82	9070	88	5338	118
	1600	8121	54	4780	72	8015	77	4717	103
	1400	7053	48	4151	64	6961	68	4097	91
	1200	5982	40	3521	54	5904	58	3475	78
	800	3843	27	2262	36	3793	39	2232	52

* Throughput (m³ h⁻¹ and cfm) = swept volume per rotation x maximum speed. cfm = ft³ min⁻¹.

† Nominal blower rotation speed.

These columns provide blower throughput (m³ h⁻¹ and cfm) and developed power (kW and h.p.) for different inlet pressures, as specified by XX%: for example, for "20%", inlet pressure = 1013 mbar (ambient atmospheric pressure) x (1 - 0.2) = 810.4 mbar absolute.

Table 6 - Vacuum performance data: sheet 1 of 5

VTBHV and SIAHV Air Injection Blowers

Blower (throughput *)	Speed † r min ⁻¹	Vacuum performance #							
		40%				50%			
		m ³ h ⁻¹	kW	cfm	h.p.	m ³ h ⁻¹	kW	cfm	h.p.
VTB810H/V (1500 m ³ h ⁻¹ 883 cfm)	3600	1427	21	840	28.2	1388	25	817	33.5
	3300	1295	19	763	25.5	1256	23	740	30.8
	3000	1160	17	683	22.8	1121	21	660	28.1
	2700	1028	16	605	21.4	989	19	582	25.5
	2400	894	14	526	18.8	855	17	503	22.8
VTB820H/V (2400 m ³ h ⁻¹ 1414 cfm)	3400	2034	28	1198	37.5	1959	35	1154	46.9
	3200	1894	26	1115	34.9	1820	33	1072	44.2
	3000	1755	25	1034	33.5	1680	31	989	41.6
	2800	1616	23	952	30.8	1541	29	908	38.9
	2600	1476	21	869	28.1	1402	27	826	36.2
SIAH/V822 (4500 m ³ h ⁻¹ 2650 cfm)	3000	3930	50	2315	67.0	3855	62	2270	83.1
	2750	3575	46	2106	61.7	3500	56	2061	75.1
	2450	3148	41	1854	55.0	3073	50	1810	67.0
	2150	2722	36	1603	48.3	2647	44	1559	59.0
	1850	2295	31	1352	41.6	2221	38	1308	50.9
SIAH/V840 (6500 m ³ h ⁻¹ 3828 cfm)	3000	5843	78	3441	104.6	5738	90	3380	120.7
	2750	5259	70	3097	93.9	5164	81	3041	108.6
	2450	4761	65	2804	87.2	4654	75	2741	100.6
	2150	3931	55	2315	73.7	3816	64	2248	85.8
	1850	2817	42	1659	56.3	2698	49	1589	65.7
SIAH/V8702 (9000 m ³ h ⁻¹ 5301 cfm)	3000	8148	101	4799	135.4	8021	127	4724	170.3
	2750	7277	91	4286	122.0	7148	115	4210	154.2
	2450	6404	81	3772	108.6	6274	102	3695	136.8
	2150	5530	71	3257	95.2	5403	89	3182	119.3
	1850	4659	61	2744	81.8	4530	77	2668	103.2
SIAH/V8902 (11160 m ³ h ⁻¹ 6573 cfm)	3000	2912	40	1715	53.6	2785	51	1640	68.4
	2000	9879	124	5815	166	9817	164	5778	220
	1800	8861	112	5215	150	8760	151	5156	189
	1600	7830	98	4609	131	7689	125	4526	168
	1400	6801	86	4003	115	6654	109	3916	146
SIAH/V8902 (11160 m ³ h ⁻¹ 6573 cfm)	1200	5768	73	3395	98	5551	94	3267	126
	800	3706	48	2181	64	3413	62	2009	84

* Throughput: see footnotes on page 8.

† Nominal blower rotation speed.

Performance: see footnotes on page 8.

Table 6 - Vacuum performance data: sheet 2 of 5

VTBHV and SIAHV Air Injection Blowers

Blower (throughput *)	Speed † r min ⁻¹	Vacuum performance #							
		60%				70%			
		m ³ h ⁻¹	kW	cfm	h.p.	m ³ h ⁻¹	kW	cfm	h.p.
VTB810H/V (1500 m ³ h ⁻¹ 883 cfm)	3600	1334	29	786	38.9	1239	34	730	45.6
	3300	1199	27	706	36.2	1106	31	651	41.6
	3000	1067	24	628	32.2	972	28	572	37.5
	2700	933	22	549	29.5	839	25	494	33.5
	2400	800	20	471	26.8	705	22	415	29.5
VTB820H/V (2400 m ³ h ⁻¹ 1414 cfm)	3400	1854	41	1092	55.0	1672	48	985	64.4
	3200	1714	39	1009	52.3	1532	45	902	60.3
	3000	1575	37	928	49.6	1393	42	820	56.3
	2800	1436	34	846	45.6	1254	39	739	52.3
	2600	1296	32	763	42.9	1115	37	657	49.6
SIAH/V822 (4500 m ³ h ⁻¹ 2650 cfm)	2200	1018	27	600	36.2	836	31	492	41.6
	3000	3748	73	2207	97.9	3565	85	2100	114.0
	2750	3393	67	1998	89.8	3209	78	1890	104.6
	2450	2966	60	1747	80.5	2783	70	1639	93.9
	2150	2540	52	1496	69.7	2357	61	1388	81.8
SIAH/V840 (6500 m ³ h ⁻¹ 3828 cfm)	1850	2114	45	1245	60.3	1930	53	1137	71.1
	1600	1758	39	1035	52.3	1575	45	928	60.3
	2600	5554	108	3271	144.8	5080	126	2992	169.0
	2340	4999	97	2944	130.1	4575	113	2695	151.5
	2165	4469	90	2632	120.7	4025	105	2370	140.8
SIAH/V8702 (9000 m ³ h ⁻¹ 5301 cfm)	1850	3616	77	2130	103.2	3175	90	1870	120.7
	1410	2491	59	1467	79.1	2070	68	1219	91.2
	800	1092	33	643	44.2	755	39	445	52.3
	2000	7837	151	4616	202.5	7521	174	4430	233.3
	1800	6964	136	4102	182.4	6648	157	3916	210.5
SIAH/V8902 (11160 m ³ h ⁻¹ 6573 cfm)	1600	6091	121	3587	162.3	5777	140	3403	187.7
	1400	5219	106	3074	142.1	4903	122	2888	163.6
	1200	4346	91	2560	122.0	4030	105	2374	140.8
	800	2601	60	1532	80.5	2285	70	1346	93.9
	2000	9006	185	5654	248	9205	224	5707	301
SIAH/V8902 (11160 m ³ h ⁻¹ 6573 cfm)	1800	8538	165	5025	221	8147	192	4795	258
	1600	7458	144	4390	193	7079	171	4167	230
	1400	6394	124	3763	166	6008	149	3536	200
	1200	5431	109	3197	146	5204	129	3063	173
	800	3137	72	1846	97	2800	86	1648	115

* Throughput: see footnotes on page 8.

† Nominal blower rotation speed.

Performance: see footnotes on page 8.

Table 6 - Vacuum performance data: sheet 3 of 5

VTBHV and SIAHV Air Injection Blowers

Blower (throughput *)	Speed † r min ⁻¹	Vacuum performance #							
		80%				90%			
		m ³ h ⁻¹	kW	cfm	h.p.	m ³ h ⁻¹	kW	cfm	h.p.
VTB810H/V (1500 m ³ h ⁻¹ 883 cfm)	3600	1009	38	594	50.9	311	42	183	56.3
	3300	875	35	515	46.9	178	39	105	52.3
	3000	742	32	437	42.9	44	35	26	46.9
	2700	608	28	358	37.5	Ø	32	Ø	42.9
	2400	476	25	280	33.5	§	§	§	§
VTB820H/V (2400 m ³ h ⁻¹ 1414 cfm)	3400	1228	54	723	72.4	214	61	126	81.8
	3200	1089	51	641	68.4	75	57	44	76.4
	3000	950	48	559	64.4	Ø	54	Ø	72.4
	2800	812	45	478	60.3	§	§	§	§
	2600	673	41	396	55.0	§	§	§	§
SIAH/V822 (4500 m ³ h ⁻¹ 2650 cfm)	3000	3119	97	1837	130.1	2097	110	1235	147.5
	2750	2764	89	1628	119.3	1741	101	1025	135.4
	2450	2338	80	1377	107.3	1315	90	774	120.7
	2150	1911	70	1125	93.9	889	79	524	105.9
	1850	1485	60	875	80.5	460	68	271	91.2
SIAH/V840 (6500 m ³ h ⁻¹ 3828 cfm)	1600	1128	52	664	69.7	105	58	62	77.8
	2600	4025	144	2371	193.1	2712	164	1596	220.0
	2340	3625	130	2135	174.3	2440	148	1436	198.5
	2165	3100	122	1826	163.6	1609	140	947	187.7
	1850	2200	102	1296	136.8	Ø	115	Ø	154.2
SIAH/V8702 (9000 m ³ h ⁻¹ 5301 cfm)	1410	1145	78	674	104.6	§	§	§	§
	800	Ø	44	Ø	59.0	§	§	§	§
	2000	6755	199	3979	266.9	4995	224	2942	300.4
	1800	5882	179	3464	240.0	4123	202	2428	270.9
	1600	5010	160	2951	214.6	3250	179	1914	240.0
SIAH/V8902 (11160 m ³ h ⁻¹ 6573 cfm)	1400	4137	140	2437	187.7	2379	157	1401	210.5
	1200	3264	120	1922	160.9	1505	135	886	181.0
	800	1519	80	895	107.3	Ø	90	Ø	254.8
	2000	8268	256	5216	344	6113	289	3790	387
	1800	7208	219	4242	294	5052	247	2974	332
SIAH/V8902 (11160 m ³ h ⁻¹ 6573 cfm)	1600	6139	196	3613	263	3983	219	2344	294
	1400	5070	171	2984	230	2915	192	1716	258
	1200	4000	147	2354	197	1844	165	1085	222
	800	1861	98	1095	131	Ø	110	Ø	148

* Throughput: see footnotes on page 8.
† Nominal blower rotation speed.
Performance: see footnotes on page 8.
Ø Inlet blanked off (data provided for information only).
§ No throughput/vacuum level unattainable.

Table 6 - Vacuum performance data: sheet 4 of 5

VTBHV and SIAHV Air Injection Blowers

Blower (throughput *)	Speed † r min ⁻¹	Vacuum performance #			
		93%			
		m ³ h ⁻¹	kW	cfm	h.p.
VTB810H/V (1500 m ³ h ⁻¹ 883 cfm)	3600	§	§	§	§
	3300	§	§	§	§
	3000	§	§	§	§
	2700	§	§	§	§
	2400	§	§	§	§
VTB820H/V (2400 m ³ h ⁻¹ 1414 cfm)	3400	§	§	§	§
	3200	§	§	§	§
	3000	§	§	§	§
	2800	§	§	§	§
	2600	§	§	§	§
SIAH/V822 (4500 m ³ h ⁻¹ 2650 cfm)	3000	Ø	114	Ø	152.9
	2750	§	§	§	§
	2450	§	§	§	§
	2150	§	§	§	§
	1850	§	§	§	§
SIAH/V840 (6500 m ³ h ⁻¹ 3828 cfm)	2600	Ø	169	Ø	226.6
	2340	§	§	§	§
	2165	§	§	§	§
	1850	§	§	§	§
	1410	§	§	§	§
SIAH/V8702 (9000 m ³ h ⁻¹ 5301 cfm)	2000	Ø	232	Ø	311.1
	1800	§	§	§	§
	1600	§	§	§	§
	1400	§	§	§	§
	1200	§	§	§	§
SIAH/V8902 (11160 m ³ h ⁻¹ 6573 cfm)	2000	Ø	299	Ø	401
	1800	§	§	§	§
	1600	§	§	§	§
	1400	§	§	§	§
	1200	§	§	§	§
	800	§	§	§	§

* Throughput: see footnotes on page 8.

† Nominal blower rotation speed.

Performance: see footnotes on page 8.

Ø Inlet blanked off (data provided for information only).

§ No throughput/vacuum level unattainable.

Table 6 - Vacuum performance data: sheet 5 of 5

2.3 Mechanical data

Dimensions VTBH and SIAH blowers VTBV and SIAV blowers Discharge/injection ports	See Figure 4 See Figure 5 See Figure 6					
Mass	VTB810H	VTB820H	SIAH822	SIAH840	SIAH8702	SIAH8902
	200 kg 441 lb	230 kg 507 lb	390 kg 860 lb	670 kg 1477 lb	1050 kg 2315 lb	1232 kg 2716 lb
	VTB810V	VTB840V	SIAV822	SIAV840	SIAV8702	SIAV8902
	205 kg 452 lb	240 kg 529 lb	390 kg 860 lb	690 kg 1521 lb	1010 kg 2227 lb	1192 kg 2628 lb

Table 7 - Mechanical data

2.4 Lubrication data

Recommended oil type VTB810H and VTB820H Other blowers	Winter/summer oil Mobil SHC 630 Mobilgear 630 or Winter/summer oil Mobil SHC 630				
Oil capacity					
Drive end cover	VTB810/820H	VTB810/820V	SIAH840	SIAV840	SIAV822
	1.1 litres 0.29 US gal	1.0 litres 0.26 US gal	4.0 litres 1.05 US gal	2.0 litres 0.52 US gal	1.73 litres 0.46 US gal
	SIAH822	SIAH8702	SIAV8702	SIAV8902	SIAH8902
	2.34 litres 0.62 US gal	7.0 litres 1.85 US gal	3.0 litres 0.79 US gal	3.0 litres 0.79 US gal	7.0 litres 1.85 US gal
Non-drive end cover	VTB810/820H	VTB810/820V	SIAH840	SIAV840	SIAV822
	0.9 litres .24 US gal	1.7 litres 0.45 US gal	3.0 litres 0.79 US gal	1.7 litres 0.45 US gal	1.51 litres 0.4 US gal
	SIAH822	SIAH8702	SIAV8702	SIAV8902	SIAH8902
	1.96 litres 0.52 US gal	6.0 litres 1.58 US gal	3.0 litres 0.59 US gal	3.0 litres 0.59 US gal	6.0 litres 1.58 US gal

Table 8 - Lubrication data

2.5 Noise and vibration data

Note: The noise and vibration data values given below are maximum values. The actual values will depend on the operating conditions.

	VTB810H/V	VTB820H/V	SIAH/V822	SIAH/V840	SIAH/V8702	SIAH/V8902
Noise level: dB(A)	120.7	128.7	127.6	123.9	123.7	124.1
Vibration level	5.5 mm s ⁻¹	6.5 mm s ⁻¹	12.5 mm s ⁻¹	6.0 mm s ⁻¹	7.5 mm s ⁻¹	7.5 mm s ⁻¹
	0.22 inch s ⁻¹	0.25 inch s ⁻¹	0.49 inch s ⁻¹	0.24 inch s ⁻¹	0.29 inch s ⁻¹	0.29 inch s ⁻¹

Table 9 - Noise and vibration data

2.6 Connections

	VTB810H/V	VTB820H/V	SIAH/V822	SIAH/V840	SIAH/V8702	SIAH/V8902
Inlet	DN125 PN10	DN150 PN10	DN200 PN10	DN300 PN10	DN300 PN10	DN300 PN10
Discharge/injection ports	See Figure 6	See Figure 6	See Figure 6	See Figure 6	See Figure 6	See Figure 6
Manifold outlet *	DN125 PN10	DN150 PN10	DN200 PN10	DN300 PN10	DN300 PN10	DN350 PN10
Earth (ground) stud	M12	M12	M12	M12	M12	M12

* Recommended size; the manifold is not supplied with the blower.

Table 10 - Connections data

2.7 Materials of construction

Casing and headplates VTB810H/V, VTB820H/V and SIAH/V8702 SIAH/V822, SIAH/V840 and SIAH/V 8902	EN GJL 200 lamellar cast iron EN GJL 250 lamellar cast iron
End covers	EN GJL 200 lamellar cast iron
Rotors	EN GJS 400-15 spheroid cast iron
Bearings	100Cr6 steel
Labyrinth seals	PTFE (polytetrafluoroethylene) ATEX only
Gaskets	Klingerit® C4430
Lip seals	Viton®
'O' rings	Nitrile

Table 11 - Construction materials data

® Klingerit is a registered trademark of Klinger AG.
Viton is a registered trademark of Dupont.

VTBHV and SIAHV Air Injection Blowers

2.8 Item Numbers

Blower model	Shaft position	Rotation direction	Standard blowers		ATEX Category 2 compliant blowers	
			Item Number	Config *	Item Number	Config*
VTB810H/V	Bottom	Anticlockwise	F1569200920	E	F1569201220	E
	Bottom	Clockwise	F1569200921	A	F1569201221	A
	Left	Anticlockwise	F1569200924	H	F1569201222	H
	Left	Clockwise	F1569200925	D	F1569201223	D
	Top	Anticlockwise	F1569200922	F	F1569201224	F
	Top	Clockwise	F1569200923	B	F1569201225	B
	Right	Anticlockwise	F1569200926	G	F1569201226	G
	Right	Clockwise	F1569200927	C	F1569201227	C
VTB820H/V	Bottom	Anticlockwise	F1557200920	E	F1557201220	E
	Bottom	Clockwise	F1557200921	A	F1557201221	A
	Left	Anticlockwise	F1557200924	H	F1557201222	H
	Left	Clockwise	F1557200925	D	F1557201223	D
	Top	Anticlockwise	F1557200922	F	F1557201224	F
	Top	Clockwise	F1557200923	B	F1557201225	B
	Right	Anticlockwise	F1557200926	G	F1557201226	G
	Right	Clockwise	F1557200927	C	F1557201227	C
SIAV822	Bottom	Anticlockwise	F1667200000	E	F1667201220	E
	Bottom	Clockwise	F1667200001	A	F1667201221	A
	Top	Anticlockwise	F1667200006	F	F1667201224	F
	Top	Clockwise	F1667200005	B	F1667201225	B
SIAH822	Left	Anticlockwise	F1670200000	H	F1670201222	E
	Left	Clockwise	F1670200001	D	F1670201223	A
	Right	Anticlockwise	F1670200006	G	F1670201226	G
	Right	Clockwise	F1670200007	C	F1670201227	C
SIAV840	Bottom	Anticlockwise	F1768200600	E	F1768201220	E
	Bottom	Clockwise	F1768200610	A	F1768201221	A
	Top	Anticlockwise	F1768200640	F	F1768201224	F
	Top	Clockwise	F1768200650	B	F1768201225	B
SIAH840	Left	Anticlockwise	F1771200600	H	F1771201220	E
	Left	Clockwise	F1771200610	D	F1771201221	A
	Right	Anticlockwise	F1771200640	G	F1771201226	G
	Right	Clockwise	F1771200650	C	F1771201227	C
SIAV8702	Bottom	Anticlockwise	F1868200100	E	F1868201220	E
	Bottom	Clockwise	F1868200101	A	F1868201221	A
	Top	Anticlockwise	F1868200501	F	F1868201224	F
	Top	Clockwise	F1868200500	B	F1868201225	B
SIAV8902	Bottom	Anticlockwise	F1869200100	E	F1869201220	E
	Bottom	Clockwise	F1869200101	A	F1869201221	A
	Top	Anticlockwise	F1869200501	F	F1869201224	F
	Top	Clockwise	F1869200500	B	F1869201225	B
SIAH8702	Left	Anticlockwise	F1871200100	H	F1871201220	E
	Left	Clockwise	F1871200101	D	F1871201221	A
	Right	Anticlockwise	F1871200102	G	F1871201226	G
	Right	Clockwise	F1871200202	C	F1871201227	C
SIAH8902	Left	Anticlockwise	F1870200200	H	F1870201220	E
	Left	Clockwise	F1870200101	D	F1870201221	A
	Right	Anticlockwise	F1870200102	G	F1870201226	G
	Right	Clockwise	F1870200202	C	F1870201227	C





Table 12 - Item Numbers

* Installation configuration: see the corresponding detail in Figure 3.

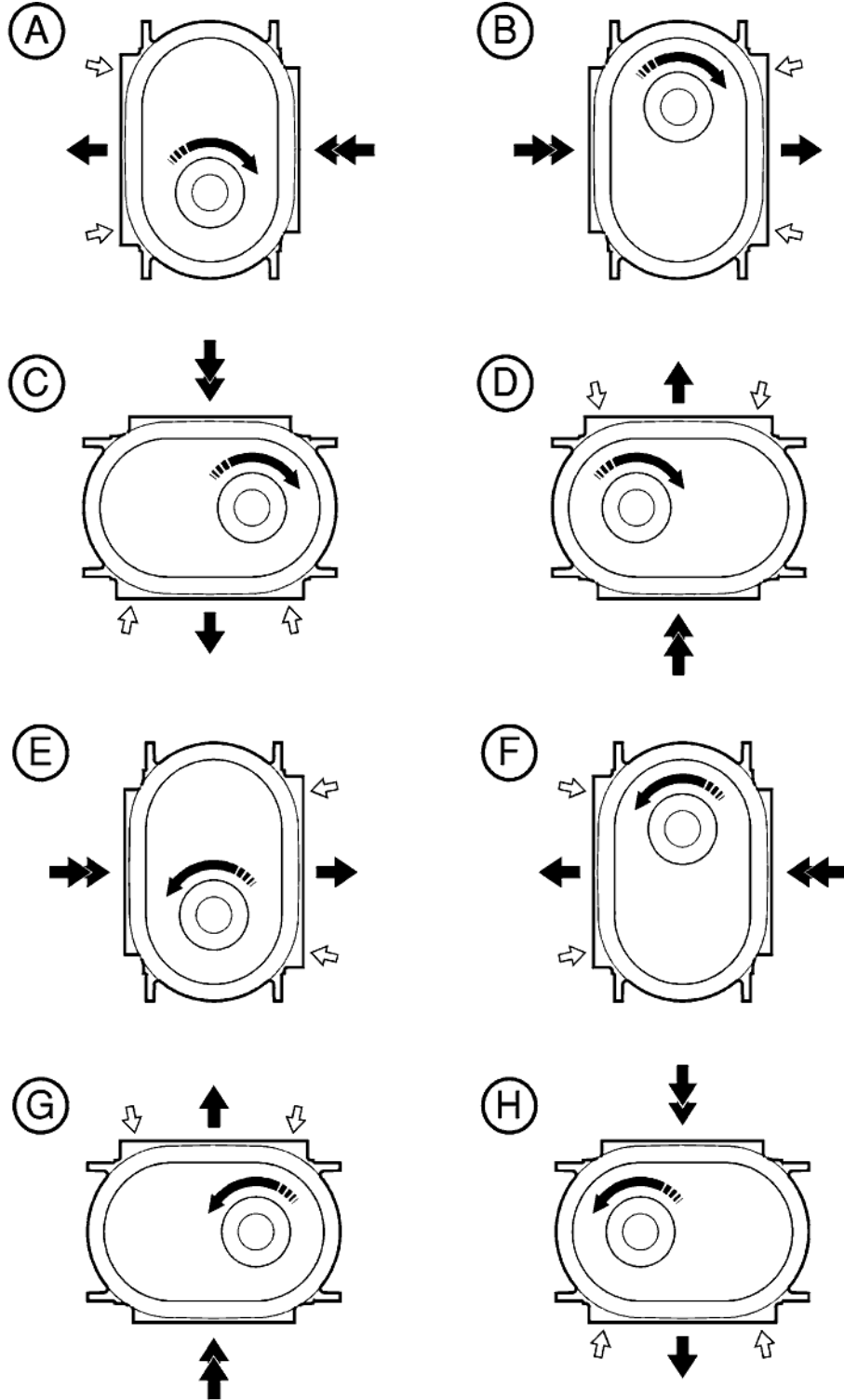
VTBH/V and SIAH/V Air Injection Blowers

AW17385/A



-  Inlet gas stream
-  Discharge (outlet) gas stream
-  Injection air
-  Direction of shaft rotation

Note: Refer to Table 12 for the Item Numbers of blowers with the configurations shown on this page.

Figure 3 - Ordering configurations

VTBH/V and SIAH/V Air Injection Blowers

Key	Dimensions: mm (inch)					
	VTB810H	VTB820H	SIAH822	SIAH840	SIAH8702	SIAH8902
A	†	†	360 (2.36)	375 (14.76)	430 (16.93)	580 (22.83)
a	†	†	36 (1.42)	46 (1.81)	50 (1.97)	50 (1.97)
B	†	†	505 (19.88)	600 (23.62)	710 (27.95)	710 (27.95)
b	†	†	30 (1.18)	35 (1.38)	40 (1.57)	40 (1.57)
C	†	†	432 (17)	467 (18.38)	530 (20.87)	680 (26.77)
D	†	†	565 (22.24)	670 (26.38)	790 (31.1)	790 (31.1)
d	†	†	85 (3.35)	84 (3.31)	100 (3.94)	100 (3.94)
E	155 (6.1)	155 (6.1)	185 (7.28)	230 (9.05)	340 (13.38)	340 (13.38)
e	†	†	75 (2.95)	107 (4.21)	90 (3.54)	90 (3.54)
F	155 (6.1)	155 (6.1)	185 (7.28)	230 (9.05)	280 (11.02)	280 (11.02)
G	†	†	25 (0.98)	20 (0.79)	20 (0.79)	20 (0.79)
H	†	†	185 (7.28)	270 (10.63)	340 (13.38)	340 (13.38)
h	†	†	185 (7.28)	270 (10.63)	340 (13.38)	
L	658 (25.9)	778 (30.63)	985 (38.78)	1127 (44.37)	1271 (50.03)	1421 (55.94)
L1	370 (14.57)	430 (16.93)	571 (22.48)	660.5 (26.00)	737 (29.01)	812 (31.97)
L2	288 (11.34)	348 (13.7)	414 (16.3)	466.5 (18.37)	534 (21.02)	609 (23.98)
N	210 (8.27)	240 (9.49)	295 (11.61)	400 (15.75)	400 (15.75)	400 (15.75)
O	125 (4.92)	150 (5.9)	200 (7.87)	300 (11.81)	300 (11.81)	300 (11.81)
P	420 (16.53)	420 (16.53)	490 (19.29)	652 (25.67)	790 (31.1)	790 (31.1)
RØr	4 [M16]	4 [M20]	8 [M20]	12 [M20]	12 Ø22 (Ø0.87)	12 Ø22 (Ø0.87)
S	†	†	Ø 22 (0.87)	Ø 22 (0.87)	Ø 27 (1.06)	Ø 27 (Ø1.06)
T	45 (1.77)	45 (1.77)	53.5 (2.11)	69 (2.72)	74.5 (2.93)	74.5 (2.93)
V	70 (2.75)	70 (2.75)	90 (3.54)	105 (4.13)	130 (5.12)	130 (5.12)
W	80 (3.15)	80 (3.15)	100 (3.94)	120 (4.72)	140 (5.51)	140 (5.51)
X	†	†	370 (14.57)	500 (19.68)	620 (24.41)	620 (24.41)
Y	12 (0.47)	12 (0.47)	14 (0.55)	18 (0.71)	20 (0.79)	20 (0.79)
Z *	42 (1.65)	42 (1.65)	50 (1.97)	65 (2.56)	70 (2.75)	Ø 70 (2.75)

* Fitting tolerance range: m6.

† The VTB810H and VTB820H blowers are supported using fixing bolt holes adjacent to the inlet and discharge (outlet) ports.

1. Elevation view showing inlet flange
2. Side view
3. Shaft/key dimensions

Figure 4 - VTBH and SIAH blower dimensions: key

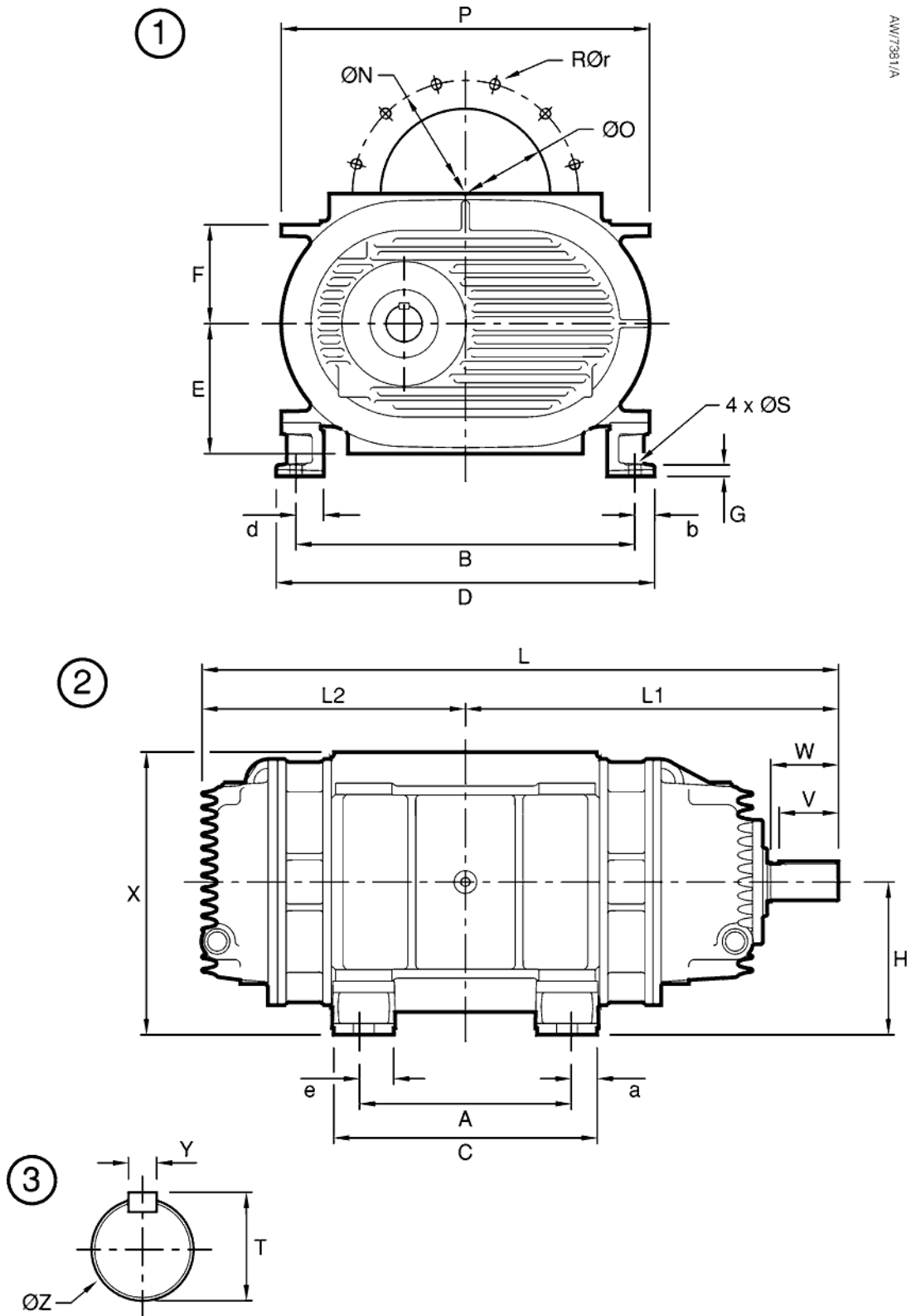

Figure 4 - VTBH and SIAH blower dimensions

VTBV and SIAV Air Injection Blowers

Key	Dimensions: mm (inch)					
	VTB810V	VTB820V	SIAV822	SIAV840	SIAV8702	SIAV8902
A	185 (7.28)	300 (11.81)	360 (2.36)	375 (14.76)	430 (16.93)	580 (22.83)
a	27.5 (1.08)	30 (1.18)	36 (1.42)	45 (1.77)	50 (1.97)	50 (1.97)
B	374 (14.72)	370 (14.57)	390 (15.35)	460 (18.11)	540 (21.26)	540 (21.26)
b	22 (0.87)	24 (0.94)	30 (1.18)	35 (1.38)	35 (1.38)	35 (1.38)
C	240 (9.45)	360 (14.17)	432 (17.0)	465 (18.31)	530 (20.87)	680 (26.77)
D	418 (16.46)	418 (16.46)	450 (17.72)	530 (20.87)	610 (24.01)	610 (24.01)
d	54 (2.13)	54 (2.13)	103 (4.05)	90 (3.54)	115 (4.53)	115 (4.53)
E	155 (6.1)	155 (6.1)	185 (7.28)	230 (9.05)	340 (13.38)	340 (13.38)
e	240 (9.45)	360 (14.17)	72 (2.83)	103 (4.05)	100 (3.94)	
F	155 (6.1)	155 (6.1)	185 (7.28)	230 (9.05)	280 (11.02)	280 (11.02)
G	10 (0.39)	10 (0.39)	25 (0.98)	35 (1.38)	20 (0.79)	20 (0.79)
H	217.5 (8.56)	217.5 (8.56)	281.5 (11.08)	343.5 (13.52)	420 (16.53)	420 (16.53)
h	15 (0.59)	150 (5.90)	195 (7.58)	235 (9.25)	285 (11.22)	285 (11.22)
L	658 (25.9)	778 (30.63)	985 (38.78)	1127 (44.37)	1271 (50.03)	1421 (55.94)
L1	370 (14.57)	430 (16.93)	571 (22.48)	660.5 (26.00)	737 (29.01)	812 (31.97)
L2	288 (11.34)	348 (13.7)	414 (16.3)	465.5 (18.33)	534 (21.02)	609 (23.98)
N	210 (8.27)	240 (9.49)	295 (11.61)	400 (15.75)	400 (15.75)	400 (15.75)
O	125 (4.92)	150 (5.9)	200 (7.87)	300 (11.81)	300 (11.81)	300 (11.81)
RØr	4 [M16]	4 [M20]	8 [M20]	12 [M20]	12 Ø22 (Ø0.87)	12 Ø22 (Ø0.87)
S	18 (0.71)	18 (0.71)	22 (0.87)	22 (0.87)	27 (1.06)	27 (1.06)
T	45 (1.77)	45 (1.77)	53.5 (2.11)	69 (2.72)	74.5 (2.93)	74.5 (2.93)
V	70 (2.75)	70 (2.75)	90 (3.54)	105 (4.13)	130 (5.12)	130 (5.12)
W	80 (3.15)	80 (3.15)	100 (3.94)	120 (4.72)	140 (5.51)	140 (5.51)
X	420 (16.53)	420 (16.53)	544.5 (21.44)	670 (26.38)	815 (32.09)	815 (32.09)
Y	12 (0.47)	12 (0.47)	14 (0.55)	18 (0.71)	20 (0.79)	20 (0.79)
Z *	42 (1.65)	42 (1.65)	50 (1.97)	65 (2.56)	70 (2.75)	70 (2.75)

* Fitting tolerance range: m6.

1. Elevation view
2. Plan view
3. Shaft/key dimensions

Figure 5 - VTBV and SIAV blower dimensions: key

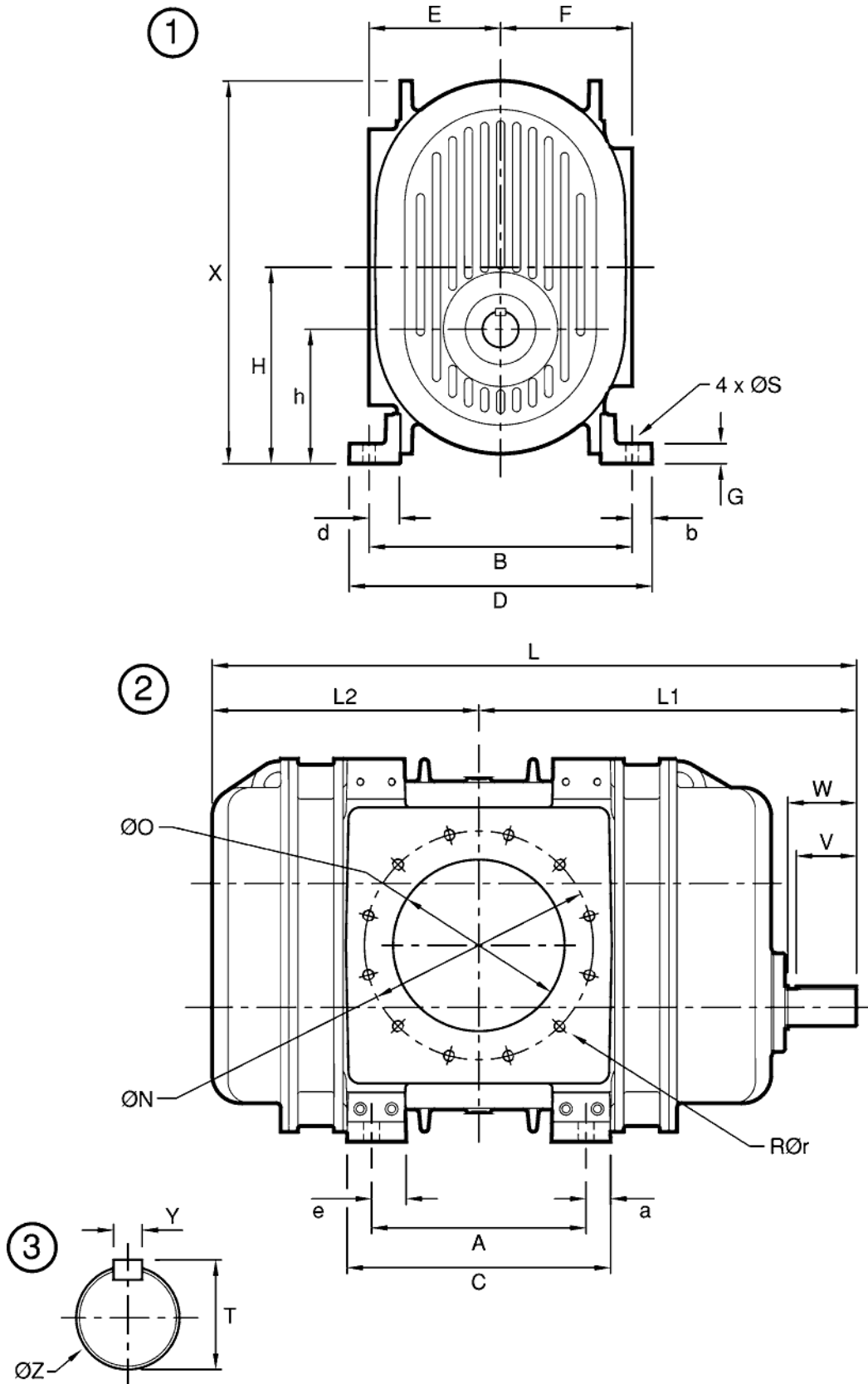
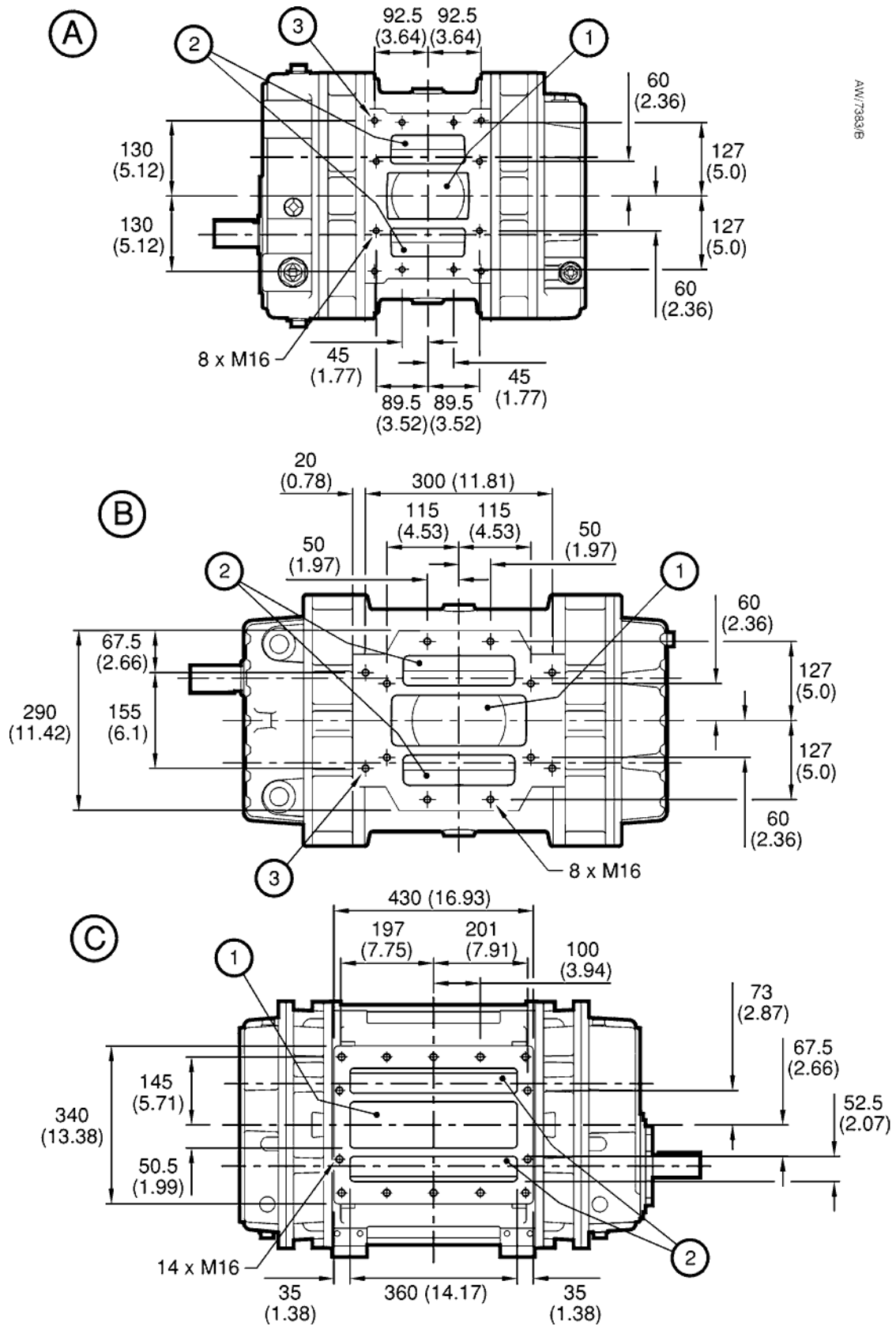

Figure 5 - VTBV and SIAV blower dimensions

VTBH/V and SIAH/V Air Injection Blowers



AW/7383/B

Figure 6 - Discharge (outlet)/injection ports dimensions: mm (inch) - sheet 1 of 2

VTBH/V and SIAH/V Air Injection Blowers

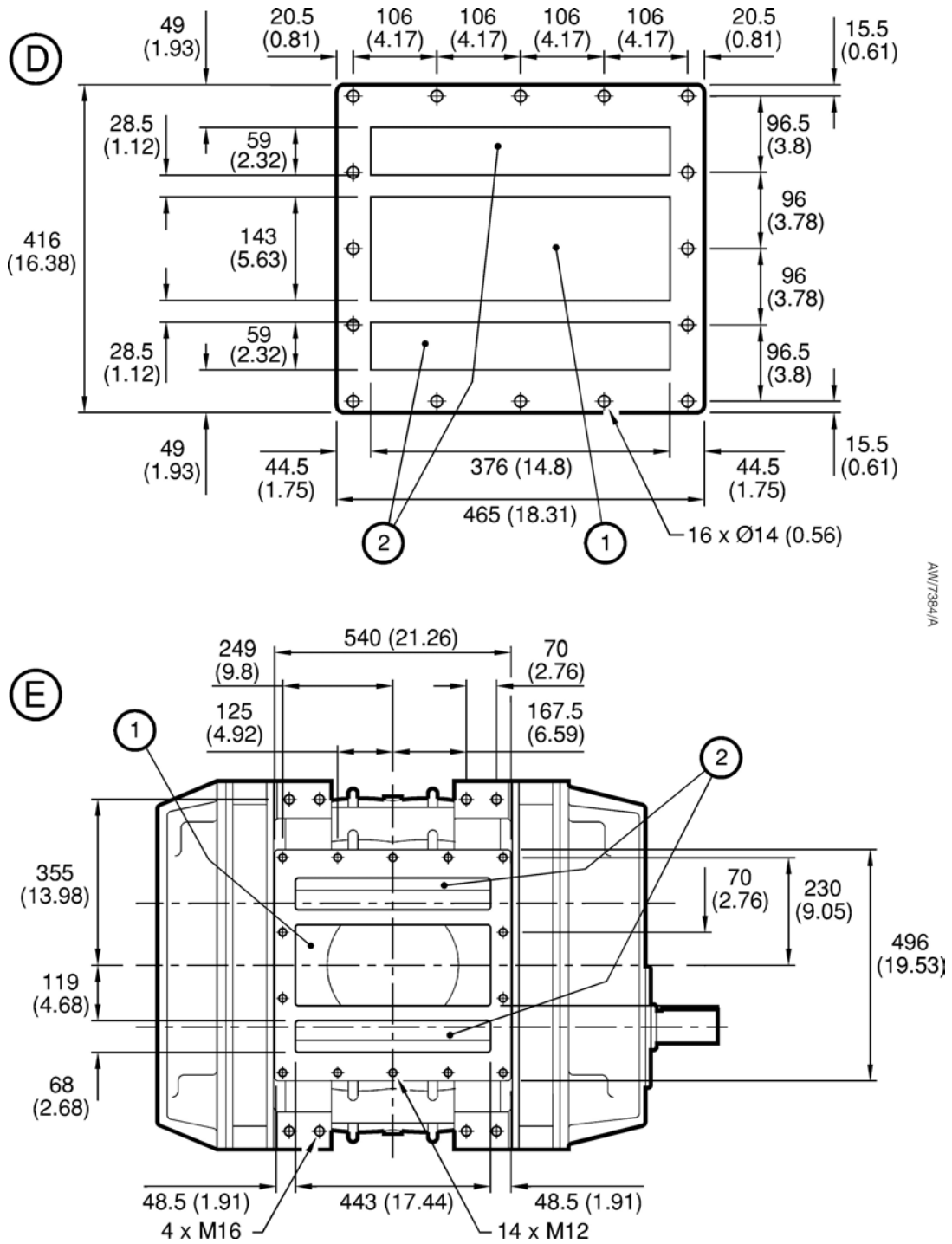

AM/7384/A

- | | | | |
|---|------------|----|-----------------------------------|
| A | VTB810H/V | 1. | Discharge (outlet) port |
| B | VTB820H/V | 2. | Injection ports (2 off) |
| C | SIAH/V822 | 3. | Blower fixing holes (4 off, M16): |
| D | SIAH/V840 | | VTB810H and VTB820H only |
| E | SIAH/V8702 | | |
| F | SIAH/V8902 | | |

Figure 6 - Discharge (outlet)/injection ports dimensions: mm (inch) - sheet 2 of 2

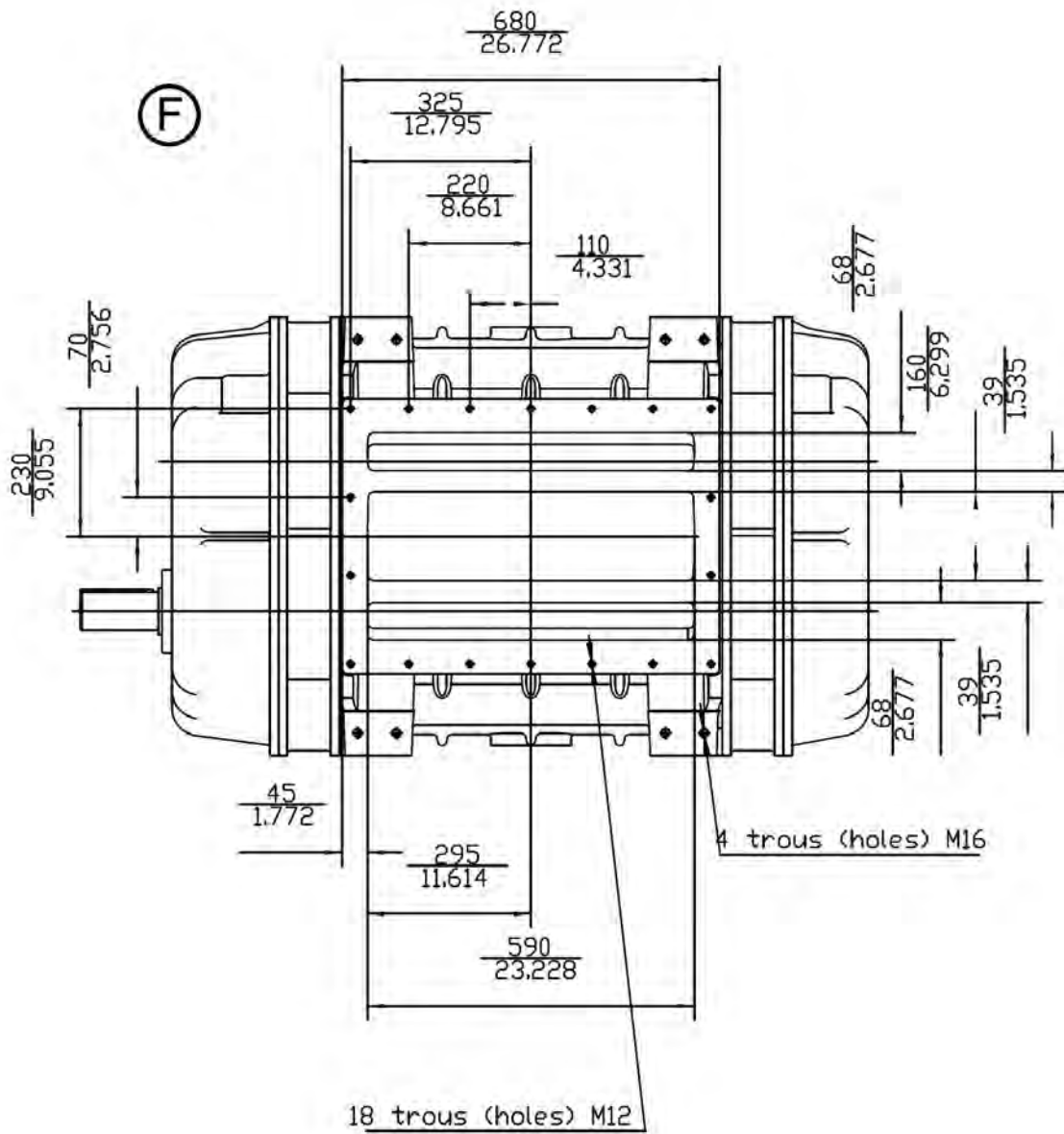
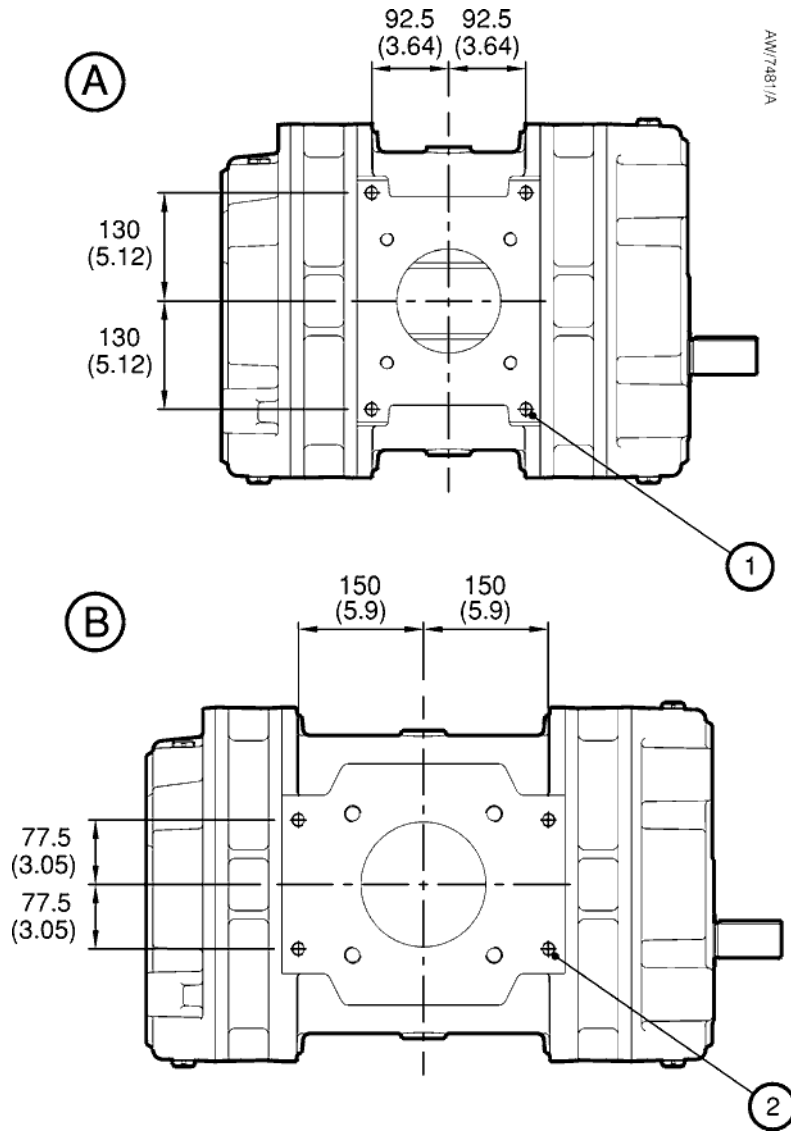

Figure 6 - Discharge (outlet)/injection ports dimensions: mm (inch)



A VTB810H
B VTB820H

1. Blower fixing holes (4 off): M16
2. Blower fixing holes (4 off): M16

Figure 7 - VTB810H and VTB820H blower fixing hole (inlet side) dimensions: mm (inch)

3 INSTALLATION

CAUTION

Ingersoll Rand will accept no liability or warranty claims if your installation includes any modifications or additions to the blower without the prior written approval of Ingersoll Rand, or if the blower is incorrectly installed.

3.1 ATEX compliant blower installation requirements

WARNING



The ATEX Category 2 blowers must be installed in accordance with the requirements detailed in this section.

The ATEX Category 2 compliant blowers **must** be installed in accordance with the installation requirements set out in this manual; This is essential for the ATEX Category 2 certification to be valid. The following requirements must be met:

- Your system design must meet the requirements specified in Section 3.3.
- Your system design must ensure that the blower is protected from the ingress of particles larger than 25 mm (9.84×10^{-5} inch) in size. Unless your design ensures that particle ingress cannot occur, use suitable filters.

3.2 Installation safety

WARNING



Obey the safety instructions listed below and take note of appropriate precautions when you install the blower.

- A suitably trained and supervised technician must install the blower.
- Ensure that debris and dust does not get into the blower when you install it.

- Check that all of the required components and tools are available and of the correct type before you start to install the blower.
- Use new suitable gaskets/seals to connect the blower into your system. Do not reuse old gaskets/seals.
- If you will fit the blower into an existing system, disconnect the power from the drive system before you start installation so that the drive system cannot be operated accidentally.

3.3 System design

3.3.1 General requirements

CAUTION

Ensure that the maximum differential pressure across the blower specified in Section 2.2 cannot be exceeded. If it is, the drive will trip and the blower will stop.

Your system must be suitably designed for correct operation of the blower. We recommend that you configure your system as shown in Figure Figure 8 (page 32) and Figure Figure 9 - (page 33). Note that:

- You must design a suitable pipeline to fit the blower inlet connection. refer to Section 2.6 and to Figures 4 and 5 for the dimensions of the blower inlet connections.
- You must design a suitable manifold (Figures Figure 8 and Figure 9 -, item 3) to fit the discharge (outlet)/ injection connections. Refer to Section 2.6 and to Figure 6 for the dimensions of these connections.

Your system design must ensure that, when the blower is in its final operating location, you can see the oil-level sight-glasses and can access the oil filler and drain plugs.

We also recommend that your system incorporates an emergency stop facility which, once activated, must be manually reset before the blower can be operated again.

(Continued on page 26)

Also note the following when you design your system:

- On ATEX Category 2 compliant blowers, you **must** incorporate filters at the blower inlet and injection inlet (see Section 3.3.2). Suitable filters and filter cartridges are available as accessories: see Section 7.3.
- If you will pump/compress flammable or toxic gases, you **must** take suitable precautions to prevent the discharge of the gases to the surrounding atmosphere.
- The blower must be sufficiently level for correct operation: see Section 3.5 for more details.
- We recommend that you incorporate silencers, to attenuate the pulsations in the inlet/outlet gas streams.
- There must be at least 150 mm (6 inches) of free space around the blower, for adequate cooling-air circulation.
- If required, install your own acoustic enclosure around the blower. If you do install such an enclosure, ensure that there is sufficient space for cooling-air flow around the blower: see above.

3.3.2 System safety

	<p>WARNING</p> <p>The ATEX Category 2 blowers must be installed in a system which complies with the requirements specified below.</p>
---	--

- Your system design must ensure that the blower cannot be operated with the inlet or discharge (outlet) pipelines obstructed.
- The gases which enter the blower must not contain solid particulates larger than 25 mm (9.84 x 10⁻⁵ inch) in size. Incorporate suitable filters to prevent the ingress of solids into the blower.

- The temperature of the gases which enter the blower must not exceed the temperature rating of the blower: see Section 1.3.2.
- Ensure that the blower cannot operate with the incorrect direction of rotation (see Section 3.10).

3.4 Unpack and inspect

	<p>WARNING</p> <p>Use suitable lifting equipment to move the blower. If you do not, you can injure yourself or damage the blower. Refer to Section 2.3 for the mass of the blower.</p>
---	---

1. Use a suitable fork-lift truck or pallet truck to move the blower, on its pallet, close to where you will install it.
2. Remove all packing materials and protective covers and check the blower. If the blower is damaged, notify your supplier and the carrier in writing within three days; state the Item Number of the blower together with your order number and your supplier's invoice number. Retain all packing materials for inspection. Do not use the blower if it is damaged.
3. Check that you have received the items listed in Table 13 (page 27). If any item is missing, notify your supplier in writing within three days
4. Look at the blower rating and identification plate (Figure 2, item 13) and check that the blower is suitable for use in your system. If the blower is not suitable for use in your system, do not continue to install the blower: contact your Supplier or Ingersoll Rand.

If the blower is not to be used immediately, replace the protective covers. Store the blower in suitable conditions, as described in Section 6.1.

VTBH/V and SIAH/V Air Injection Blowers

Quantity	Description	Check (3)
1	VTBH/V or SIAH/V blower	0
1	Discharge (outlet)/injection gasket	0
*	Winter/summer oil Mobil SHC 630	0

* If you have ordered oil, you will receive sufficient quantity of oil to fill the blower: see Section 2.4.

Table 13 - Checklist of items

3.5 Locate the blower

3.5.2 Other blowers

3.5.1 VTB810H and VTB820H blowers



WARNING

Use suitable lifting equipment to move the blower. If you do not, you can injure yourself or damage the blower. Refer to Section 2.3 for the mass of the blower.



WARNING

Use suitable lifting equipment to move the blower. If you do not, you can injure yourself or damage the blower. Refer to Section 2.3 for the mass of the blower.

The VTB810H and VTB820H blowers have blower fixing holes adjacent to the inlet port (see Figure Figure 7 -) and to the discharge (outlet) port (see Figure 6). Use these fixing holes to secure the VTB810H or VTB820H blower in its required operating location.

You must ensure that, when in its required operating location, the blower is sufficiently level. (The blower can operate with a maximum slope of 15° in any of the horizontal mounting axes.)

Use the following procedure to locate a VTB810H or VTB820H blower:

1. Refer to Figure 2. Attach suitable lifting equipment to the four lifting-bolts (1), then use the lifting equipment to move the blower to its required operating location.
2. Use the blower fixing holes to secure the blower to suitable supports in your system.
3. Disconnect your lifting equipment from the lifting-bolts. If required, remove the lifting-bolts from the blower.

You must provide a firm, level platform for the blower. Ensure that the operating location is clean and free from debris and oil.

You must ensure that when the blower is in its required operating location:

- Both of the mounting plates are flat on the platform.
- The blower is sufficiently level. (The blower can operate with a maximum slope of 15° in any of the horizontal mounting axes.)

Use the following procedure to locate the blower:

1. Refer to Figure 2. Attach suitable lifting equipment to the four lifting-bolts (1), then use the lifting equipment to move the blower to its required operating location.
2. Disconnect your lifting equipment from the lifting-bolts. If required, remove the lifting-bolts from the blower.
3. Fit suitable bolts through the fixing holes in the mounting plates (9), to secure the blower in position.

3.6 Connect the blower into your system

Take note of the following when you connect the blower into your system:

- For optimum performance, ensure that the system pipelines connected to the blower are as short as possible.
- Support your system pipelines and other components, to prevent loading of the inlet and discharge (outlet)/injection flanges on the blower.
- Incorporate flexible components in your system, to minimise noise and vibration.
- Use gaskets/seals which are compatible with the gases which will be pumped/compressed, and with the operating conditions. (Note that a gasket is supplied with the blower for the discharge (outlet)/injection connection.)
- The leak tightness of your system connections must be in accordance with the requirements of your applications.

Use the following procedure to connect the blower into your system:

1. Use a suitable gasket/seal to connect your inlet pipeline to the blower inlet (Figure 2, item 1).
2. Use the gasket supplied to connect your manifold (Figures Figure 8 and Figure 9 -, item 3) to the blower discharge (outlet)/air injection connections (Figure 2, item 3).

3.7 Fill the blower with oil

	<p>WARNING</p> <p>Ensure that you use the correct grade of oil and that the oil levels are correct. If you do not, surfaces in the blower may get hot and become potential sources of ignition.</p>
---	--

1. Drain the protective oil from the drive end and non-drive end covers: refer to Section 5.6.
2. Use a suitable cleaning solution (such as alcohol or white spirit) to clean the rotors:
 - Moisten a suitable clean, lint-free cloth with the cleaning solution.
 - Clean the rotors (Figure 2, item 8) which are visible through the inlet port.
 - Turn the blower drive shaft as necessary to access the other rotors.
3. Refer to Figure 2. Fill the drive end cover (4) with oil: refer to Section 5.6.1.
4. Fill the non-drive end cover (12) with oil: refer to Section 5.6.2.

3.8 Connect the blower to earth (ground) (ATEX compliant blowers only)

	<p>WARNING</p> <p>You must connect the blower to earth (ground) to ensure that static electricity cannot create an ignition source.</p>
---	--

1. Refer to Figure 2 detail E. Connect one end of a suitable earth (ground) conductor to one of the earth (ground) studs (20).
2. Connect the other end of the conductor to a suitable earth (ground) point on your system.
3. Ensure that there is electrical continuity of the new earth (ground) connection.

3.9 Fit the drive/transmission



WARNING
Your drive and transmission system design must ensure that the maximum blower rotational speed specified in Section 2.2 cannot be exceeded.



WARNING
You must fit suitable guards to protect people from rotating/moving parts.

Your drive and transmission system design must ensure that the radial and axial loadings on the blower drive shaft are as low as possible. The radial and axial loadings **must** be below the maximum loadings specified in Table 14.

Connect the components of the drive and transmission system to the blower drive shaft (Figure 2, item 5) as described in the manufacturer’s instructions supplied with the components.

You must use a suitable coupling or a belt drive and transmission system to connect your drive to the blower.

Blower	Maximum loadings (N)		Maximum loadings (lbf)	
	Radial	Axial	Radial	Axial
VTB810H/V	1.12×10^3	1.3×10^2	2.52×10^2	2.92×10^2
VTB820H/V	1.72×10^3	2.1×10^2	3.87×10^2	4.72×10^1
SIAH/V822	3.5×10^3	4.2×10^2	7.87×10^2	9.44×10^1
SIAH/V840	6.02×10^3	7.2×10^2	1.35×10^3	1.62×10^2
SIAH/V8702	1.069×10^4	1.28×10^3	2.4×10^3	2.88×10^3
SIAH/V8902	1.069×10^4	1.28×10^3	2.4×10^3	2.88×10^3

Table 14 - Maximum drive shaft loadings

3.10 Check the direction of rotation

	<p>WARNING</p> <p>If you remove a guard during the following procedure, ensure that you do not come into contact with the shaft, the coupling/belt or the drive system when you operate the blower. If you do, you may be injured by the rotating components.</p>
---	--

	<p>WARNING</p> <p>Ensure that the blower rotates in the correct direction. If it does not, the blower and your system can become pressurised, or will not operate correctly, when you switch on the blower drive.</p>
---	--

Check the direction of rotation of the blower as follows:

1. If necessary (that is, to make it easier to see the blower drive shaft), temporarily remove any guard over the drive coupling or belt.
2. Refer to Figure 2. Watch the blower drive shaft (5) while you start up the blower (refer to Section 4.2), then shut down the blower (refer to Section 4.3) after two seconds or so.
3. Check that the blower drive shaft (5) rotated correctly in the direction shown by the arrow (15) on the drive end cover (4).
4. If the direction of rotation was incorrect:
 - Check the installation of the drive and transmission system and reconfigure as appropriate.
 - Perform the direction of rotation check from Step 2 again, to ensure that the blower now rotates in the correct direction.
5. If you have removed the guard over the drive coupling or belt (as in Step 1 above), refit the guard.

4 OPERATION

CAUTION

Ingersoll Rand will accept no liability or warranty claims if your blower is used on applications or in a way prohibited in this manual, or not specified in this manual.

Note: The procedures in the following sections assume that your system is configured as shown in Figures Figure 8 and Figure 9 -.

4.1 General operational safety

WARNING

Obey the safety instructions and precautions listed below. If you do not, there may be a risk of injury or death to people, or damage to the blower.

- You must operate an ATEX compliant blower with the valves opened/closed as specified in Sections 4.2.1 and 4.2.2, otherwise the temperature classification of the blower will be exceeded (refer to Section 1.3.2).
- Do not operate the blower when the cooling-air flow around the blower is restricted (see Section 3.3.1). If you do, the blower may overheat and (on ATEX compliant blowers) the temperature classification of the blower may be exceeded (refer to Section 1.3.2).
- Do not operate the blower with the blower suction inlet or discharge (outlet)/injection connections open to the atmosphere. If you do, your fingers or other parts of your body or clothing may get trapped, and you may be injured by the rotating mechanisms in the blower.
- Do not operate the blower with the guards removed from the blower drive shaft, the coupling/belt or the drive system. If you do, your fingers or other parts of your body or clothing may get trapped, and you may be injured by the rotating components.

- Prevent accidental contact with the hot blower, and do not place flammable materials on the blower. During operation, the temperature of external parts of the blower can exceed 70 °C (158 °F).
- Never disconnect any of the connecting pipelines (for example, the pipeline connected to the inlet) when the blower is operating.
- During pressure operation, prevent accidental contact with the discharged (outlet) gas stream. This gas stream will be at high pressure and will be hot and can cause burn injury.
- Do not attempt to use the blower to pump/compress liquids. The blowers are not designed for this application.
- Where necessary (for example, if you have not fitted an acoustic enclosure), wear suitable ear defenders. The blower can be noisy during operation (refer to Section 2.5).

4.2 Start-up

4.2.1 Pressure operation

1. Check the oil-levels in the blower: refer to Section 5.4.
2. Refer to Figure Figure 8. Ensure that the valves in your system are in the correct positions:

Valve	Position
V1	Closed
V2	Closed
V3	Closed
V4	Open
V5	Open

3. Engage your drive and transmission system to start the blower.
4. Leave the blower to operate until the temperature of the discharge (outlet) gas stream is 85 °C (185 °F). (This may take up to 10 minutes, depending on your system design.)

You can now use the blower as required in your application.

AW/7396/A

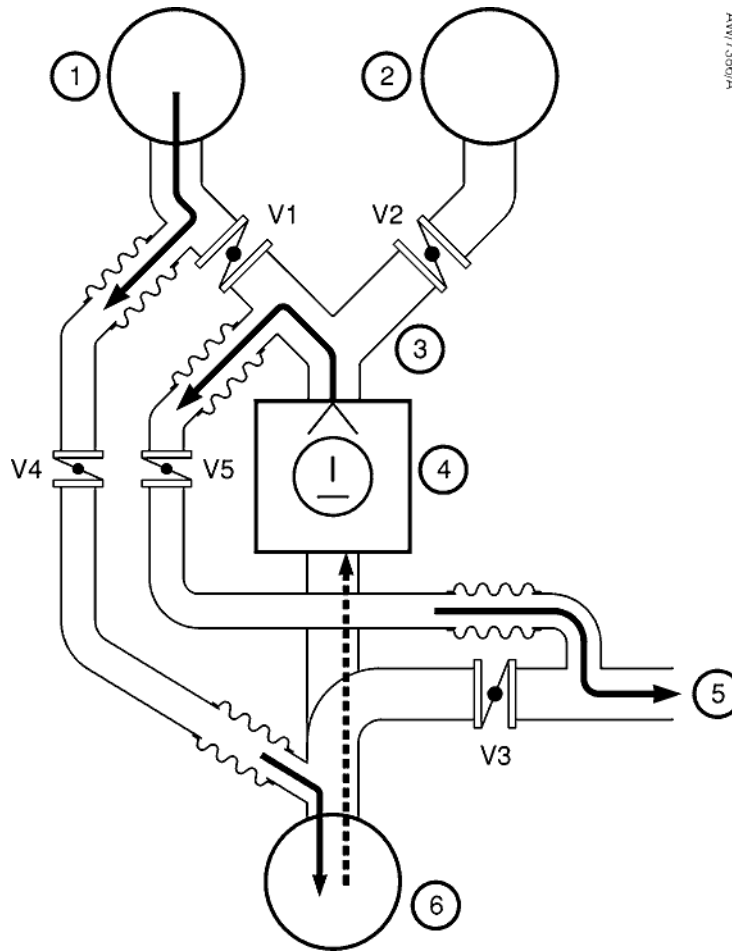

1. Inlet/outlet silencer
2. Air injection silencer/filter
3. Discharge (outlet)/injection manifold
4. VTBH/V or SIAH/V blower
5. System inlet/outlet
6. Filter *

- V1 Inlet/outlet silencer isolation valve
- V2 Injection isolation valve
- V3 System inlet/outlet isolation valve
- V4 Inlet bypass valve
- V5 Discharge bypass valve

* Optional for standard blowers, mandatory for ATEX Category 2 compliant blowers

Valve settings for correct operation

Valve	Position
V1	Closed
V2	Closed
V3	Closed
V4	Open
V5	Open

Note: On ATEX compliant blowers, valves V4 and V5 must always be open when V2 is closed, in order to ensure that the temperature classification is not exceeded.

Figure 8 - Recommended system configuration: pressure operation

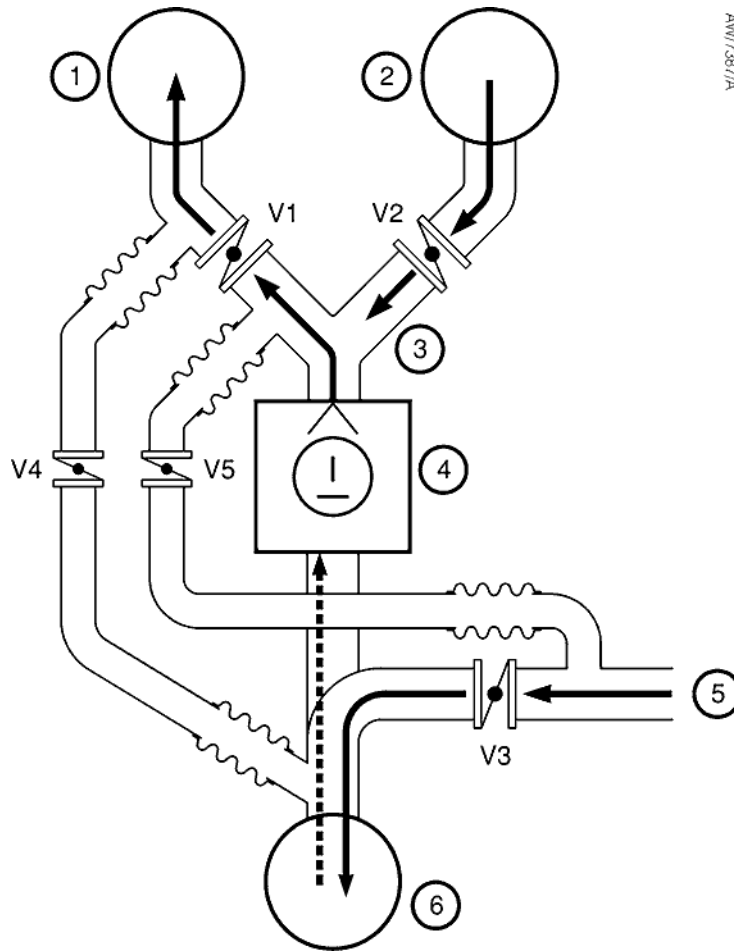

- 1. Inlet/outlet silencer
- 2. Air injection silencer/filter
- 3. Discharge (outlet)/injection manifold
- 4. VTBH/V or SIAH/V blower
- 5. System inlet/outlet
- 6. Filter *

- V1 Inlet/outlet silencer isolation valve
- V2 Injection isolation valve
- V3 System inlet/outlet isolation valve
- V4 Inlet bypass valve
- V5 Discharge bypass valve

* Optional for standard blowers, mandatory for ATEX Category 2 compliant blowers

Valve settings for correct operation

Valve	Position
V1	Open
V2	Open
V3	Open
V4	Closed
V5	Closed

Note: On ATEX compliant blowers, valves V4 and V5 must always be closed when V2 is open, in order to ensure that the temperature classification is not exceeded.

Figure 9 - Recommended system configuration: vacuum operation

4.2.2 Vacuum operation

	WARNING
Do not expose any part of your body to vacuum. If you do, you may be injured.	

1. Check the oil-levels in the blower: refer to Section 5.4.
2. Refer to Figure Figure 9 -. Ensure that the valves in your system are in the correct positions:

Valve	Position
V1	Open
V2	Open
V3	Open
V4	Closed
V5	Closed

3. Engage your drive and transmission system to start the blower.
4. Slowly close valve V3 (the system inlet/outlet isolation valve) to obtain a vacuum level of approximately 500 mbar (5×10^4 Pa, 375 Torr).
5. Leave the blower to operate for 10 minutes or more.
6. Fully open valve V3 (the system inlet/outlet isolation valve).

You can now use the blower as required in your application.

4.3 Shut-down

4.3.1 Pressure operation

	WARNING
On ATEX compliant blowers, you must disengage the drive and transmission to stop the blower within 1 minute of closing valve V4. If you do not, the temperature classification will be exceeded.	

Refer to Figure Figure 8 and shut down the blower as follows:

1. Slowly close valve V4 (the inlet bypass valve).
2. Disengage the drive and transmission system to stop the blower within 1 minute: see Warning above.

4.3.2 Vacuum operation

	WARNING
Do not expose any part of your body to vacuum. If you do, you may be injured.	

Refer to Figure Figure 9 - and shut down the blower as follows:

1. Slowly close valve V3 (the system inlet/outlet isolation valve).
2. Leave the blower to operate for sufficient time to purge any gases from the blower.
3. Disengage the drive and transmission system to stop the blower.

5 MAINTENANCE

5.1 Safety Information



WARNING

Obey the safety instructions given below and take note of appropriate precautions. If you do not, you can cause injury to people and damage to equipment.

- A suitably trained and supervised technician must maintain the blower. Obey your local and national safety requirements.
- Ensure that the maintenance technician is familiar with the safety procedures which relate to the gases pumped/compressed by the system in which the blower is installed.
- Allow the blower to cool to a safe temperature before you start maintenance work.
- Isolate the blower from the drive system so that it cannot be operated accidentally.
- Recheck the blower rotation direction (see Section 3.10) if the drive and transmission system has been disconnected and then reconnected.
- Take care to protect sealing faces from damage.
- Do not reuse seals/gaskets if they are damaged.

- Do not touch or inhale the thermal breakdown products of fluorinated materials which may be present if the blower has been heated to 260 °C (500 °F) and above. These breakdown products are very dangerous. Fluorinated materials in the blower include seals. The blower may have overheated if it was misused, if it malfunctioned or if it was in a fire. Ingersoll Rand Material Safety Data Sheets for fluorinated materials used in the blower are available on request: contact your supplier or Ingersoll Rand.
- Check the leak tightness of the system connections after maintenance work is complete if you have connected or disconnected any suction inlet or discharge (outlet)/injection joints. The leak tightness of the system connections must be in accordance with the requirements of your applications.

5.2 Maintenance plan

The plan in Table 15 (page 36) details the maintenance operations required to maintain the blower in normal operation. Instructions for each operation are given in the section shown.

Note that, for ATEX Category 2 compliant blowers, you **must** maintain the blower in accordance with (or more frequently than) the frequencies specified in Table 15, in order to ensure ATEX compliance.

When you maintain the blower, use Ingersoll Rand spares: refer to Section 7.3.

Operation	Frequency	Refer to Section
Inspect the oil-level sight-glasses	Weekly	5.3
Check the oil-levels	Weekly	5.4
Inspect the system installation	Monthly	5.5
Change the oil	Yearly	5.6
Overhaul the blower	3 yearly (VTB820H/V) * 5 yearly (other blowers) *	5.7

* These maintenance frequencies are based upon a maximum blower usage of 2000 hours per year. If your blower usage exceeds this, you must adjust the maintenance frequency for your blower accordingly.

Table 15 - Maintenance plan

5.3 Inspect the oil-level sight-glasses

- Refer to Figure 2. Look at the oil-level sight-glass (6) on the drive end cover (4):
 - If the sight-glass is dirty, use a suitable cloth to wipe it clean.
 - If the sight-glass is damaged (that is, scratched, cracked or corroded), or if there are signs of oil leakage from the sight-glass, you must replace it: contact your supplier or Ingersoll Rand.
- Look at the oil-level sight-glass (11) on the non-drive end cover (12):
 - If the sight-glass is dirty, use a suitable cloth to wipe it clean.
 - If the sight-glass is damaged (that is, scratched, cracked or corroded), or if there are signs of oil leakage from the sight-glass, you must replace it: contact your supplier or Ingersoll Rand.

5.4 Check the oil levels



WARNING
Ensure that you use the correct grade of oil and that the oil levels are correct. If you do not, surfaces in the blower may get hot and become potential sources of ignition.

5.4.1 Drive end cover

- Refer to Figure 2, detail D. Look at the oil level in the sight-glass (6) on the drive end cover (4):
 - If the oil level is below the minimum level mark (19), continue at Step 2 to add more oil.
 - If the oil level is above the maximum level mark (18), drain oil from the blower until the level is correct: refer to Section 5.6.
- Refer to detail C. Remove the oil filler-plug (16) from the filler port on the top of the drive end cover (4).

3. Pour new oil of the correct type (see Section 2.4) through the filler port and into the end cover until the oil-level reaches the maximum level mark (detail D, item 18). If the oil level goes above the maximum level mark (18), drain oil from the blower until the level is correct: refer to Section 5.6.
4. Refit the oil filler-plug (16) to the filler port on the top of the drive end cover (4).

5.4.2 Non-drive end cover

1. Refer to Figure 2, detail D. Look at the oil level in the sight-glass (11) on the non-drive end cover (12):
 - If the oil level is below the minimum level mark (19), continue at Step 2 to add more oil.
 - If the oil level is above the maximum level mark (18), drain oil from the blower until the level is correct: refer to Section 5.6.
2. Refer to detail C. Remove the oil filler-plug (17) from the filler port on the top of the non-drive end cover (12).
3. Pour new oil of the correct type (see Section 2.4) through the filler port and into the end cover until the oil-level reaches the maximum level mark (detail D, item 18). If the oil level goes above the maximum level mark (18), drain oil from the blower until the level is correct: refer to Section 5.6.
4. Refit the oil filler-plug (17) to the filler port on the top of the non-drive end cover (12).

5.5 Inspect the system installation

Note: Where possible, we recommend that you investigate the cause of any damage or corrosion, and implement corrective measures to prevent any future damage of components.

Use the following procedure to inspect the system connections:

1. Inspect all of the system pipelines and connections and check that they are not damaged or corroded and that they are sufficiently leak-tight. Repair or replace any damaged or corroded component and seal any leak found.
2. On ATEX Category 2 compliant blowers only: check that the earth (ground) connection is secure (see Section 3.8). If necessary, refit the connection, or make a new connection.
3. Inspect the drive/transmission system and adjust, repair or replace as necessary: refer to the manufacturer's instructions supplied with your drive/transmission system.

5.6 Change the oil**WARNING**

Ensure that you use the correct grade of oil and that the oil levels are correct. If you do not, surfaces in the blower may get hot and become potential sources of ignition.

5.7 Overhaul the blower

The blower must be regularly overhauled, as specified in Table 15. As part of the overhaul, the bearings in the blower must be replaced.

We recommend that you contact your supplier or Ingersoll Rand to arrange for an overhaul of the blower.

5.8 Fault finding

A guide to fault conditions and their possible causes is provided in Table 16 to assist you in basic fault finding.

If you are unable to rectify a fault when you use this guide, call your supplier or your nearest Ingersoll Rand Service Centre for advice.

Note: If you have been approved to carry out strip-down, repair and reassembly of your blower, refer to the Service Manual supplied separately for detailed procedures.

5.6.1 Drive end cover

1. Refer to Figure 2 detail C. Remove the oil filler-plug (16) from the filler port on the top of the drive end cover (4).
2. Refer to detail A. Place a suitable container under the drain plug (7) on the drive end cover. The container must have a maximum capacity as specified in Table 8.
3. Remove the oil drain plug (7) from the end cover, and allow the oil to drain from the end cover into the container.
4. Refit the oil drain plug (7) to the drive end cover (4).
5. Dispose of the oil: refer to Section 6.2.
6. Fill the drive end cover with new oil of the correct type and grade: refer to Section 5.4.1.

5.6.2 Non-drive end cover

1. Refer to Figure 2 detail C. Remove the oil filler-plug (17) from the filler port on the top of the non-drive end cover (12).
2. Refer to detail A. Place a suitable container under the drain plug (10) on the non-drive end cover. The container must have a maximum capacity as specified in Table 8.
3. Remove the oil drain plug (10) from the end cover, and allow the oil to drain from the end cover into the container.
4. Refit the oil drain plug (10) to the non-drive end cover (12).
5. Dispose of the oil: refer to Section 5.4.1.
6. Fill the non-drive end cover with new oil of the correct type and grade: refer to Section 5.4.2.

VTBH/V and SIAH/V Air Injection Blowers

Symptom	Check	Actions
The blower will not start, or seizes during operation.	<p>Are the rotors touching ?</p> <p>Has the blower been overloaded ?</p> <p>Has debris or foreign material entered the blower ?</p> <p>Is the drive/transmission system faulty ?</p>	<p>Check the rotor clearances and adjust as necessary.</p> <p>Check the required operating conditions and specified performance of the blower (see Section 2).</p> <p>Strip down, clean and repair the blower as necessary.</p> <p>Check that your drive and transmission system is operating correctly, and that it is correctly fitted to the blower: refer to Section 3.9 and to the manufacturer's instructions.</p>
The blower is noisy during operation.	<p>Are the rotors touching ?</p> <p>Are the gear and/or bearing clearances incorrect ?</p> <p>Are the rotors unbalanced ?</p>	<p>Check the rotor clearances and adjust as necessary.</p> <p>Check the clearances and adjust as necessary.</p> <p>Clean the rotors and rotor housing, then check the rotor clearances and adjust as necessary.</p>
The blower overheats.	<p>Is the suction inlet filter blocked ?</p> <p>Is the differential pressure across the blower too high ?</p> <p>Is an oil level too high, or has the incorrect grade of oil been used ?</p> <p>Are the rotor or rotor/casing clearances incorrect ?</p> <p>Does your enclosure provide inadequate cooling ?</p>	<p>Clean or replace the filter.</p> <p>Check that your system design complies with the requirements of Section 3.3, and that the blower is suitable for use in your application.</p> <p>Check the oil levels (refer to Section 5.4) or drain the blower and fill with the correct grade of oil (refer to Section 5.6).</p> <p>Contact your supplier or Ingersoll Rand for advice.</p> <p>If you have fitted an acoustic enclosure around the blower:</p> <ul style="list-style-type: none"> • Ensure that the enclosure cooling vents/louvres are unobstructed. • Ensure that the enclosure cooling/extraction fan is operating correctly. • Ensure that there is sufficient clearance for cooling-air flow around the blower: refer to Section 3.3.1.

Table 16 - Fault finding (Sheet 1 of 2)

Symptom	Check	Actions
There is oil in the gas stream from the blower.	Is an oil level too high ? Have the sealing rings failed ?	Check the oil level and if necessary drain oil from the blower: refer to Section 5.4. Contact your supplier or Ingersoll Rand for advice.
Oil leaks from the drive shaft.	Have the lip seals failed ?	Inspect the lip seals and replace if necessary.
There is a low volume flow through the blower.	Is the suction filter blocked ? Is the blower worn or damaged ? Is the blower unsuitable for your application ?	Clean or replace the filter. Contact your supplier or Ingersoll Rand for advice. If necessary, redesign your system to comply with the capabilities of the blower, or fit a different blower which provides the necessary performance.
Absorbed power is too high.	Is the blower unsuitable for your application ? Is the suction filter blocked ?	If necessary, redesign your system to comply with the capabilities of the blower, or fit a different blower which provides the necessary performance. Clean or replace the filter.
The blower rotates in reverse direction when you stop it.	Is your non-return valve defective ?	Check that the non-return valve between the manifold and the discharge (outlet) filter operates correctly. Repair or replace as necessary.
-	-	If you have made the checks/actions as described above and you still cannot identify the cause of a fault, or if you cannot rectify a fault, contact your supplier or Ingersoll Rand for advice.

Table 16 - Fault finding (Sheet 2 of 2)

6 STORAGE AND DISPOSAL

6.1 Storage

6.1.1 Preparation

1. Shut down the blower as described in Section 4.3.
2. If necessary, disconnect the drive and transmission system from the blower drive shaft: refer to the manufacturer's instructions supplied with your transmission system.
3. If necessary, purge your system and the blower with dry air, and disconnect the blower from your system pipelines.
4. Place and secure protective covers over the blower suction inlet, discharge (outlet) and injection inlet flanges.
5. Use suitable lifting equipment to move the blower to its storage area: refer to Section 3.5.
6. If you will store the blower for longer than six weeks, refer to the requirements in Section 6.1.2.
7. Store the blower in clean, dry conditions in a well-ventilated place that is free from vibration or shocks.

6.1.2 Long-term storage

If the blower is to be stored for longer than six weeks:

1. Drain the oil from the drive end and non-drive end covers: refer to Section 5.6.

2. Fill the drive end and non-drive end covers with a suitable protective oil (see Table 17): use the method in Section 5.4.
3. Turn the blower drive shaft by hand through three or four revolutions, to turn the blower and prevent seizure.
4. Spray a suitable protective oil (see Table 17) through the inlet and into the blower.
5. If required, spray a suitable protective oil (see Table 17) on the outer surfaces of the blower, to inhibit corrosion.

During storage, every 14 days or less, turn the blower drive shaft by hand through a quarter of a revolution, to turn the blower and prevent seizure or degradation of the bearings.

When required for use after storage:

1. Drain the protective oil from the drive end and non-drive end covers, then fill the end covers with new oil: refer to Section 5.6.
2. Use a suitable cleaning solution (such as alcohol or white spirit) to clean the rotors:
 - Moisten a suitable clean, lint-free cloth with the cleaning solution.
 - Clean the rotors which are visible through the inlet port.
 - Turn the blower drive shaft as necessary to access the other rotors.
3. Prepare and install the blower as described in Section 3.

External components	Internal components
Rust Ban 324 (Esso)	Mobilarma 523/524 (Mobil)
V Product 9703 (Shell)	Esso Lub MZ 20E/20 (Esso)
Mobilarma 778 (Mobil)	Ensis Motor Oil 20 (Shell)

Table 17 - Suitable protective oils

6.2 Disposal

	<p>WARNING</p> <p>Ensure that you wear the appropriate Personal Protective Equipment (PPE) when you handle contaminated oil or contaminated components.</p>
---	--

Safely dispose of the blower, used oil and any components in accordance with all local and national safety and environmental requirements.

Take particular care with the following:

- Used oil that has been contaminated with dangerous substances.
- Components that have been contaminated with dangerous substances.

7 SERVICE, SPARES AND ACCESSORIES

7.1 Introduction

Ingersoll Rand products, spares and accessories are available from Ingersoll Rand companies in Belgium, Brazil, China, France, Germany, Israel, Italy, Japan, Korea, Singapore, United Kingdom, USA and a world-wide network of distributors. The majority of these employ service engineers who have undergone comprehensive Ingersoll Rand training courses.

Order spare parts and accessories from your nearest Ingersoll Rand company or distributor. When you order, please state for each part required:

- Model and Item Number of your equipment
- Serial number (if any)
- Item Number and description of the part

7.2 Service

Ingersoll Rand products are supported by a world-wide network of Ingersoll Rand Service Centres. Each Service Centre offers a wide range of options including: equipment decontamination; service exchange; repair; rebuild and testing to factory specifications. Equipment which has been serviced, repaired or rebuilt is returned with a full warranty.

Your local Service Centre can also provide Ingersoll Rand engineers to support on-site maintenance, service or repair of your equipment.

For more information about service options, contact your nearest Service Centre or other Ingersoll Rand company.

7.3 Spares and accessories

The spares and accessories available for the blowers are shown in Table 18 (page 44).

Note that, for cartridges/filters:

- 'type F' specifies a flanged component.
- 'type C' specifies a component which must be fitted with a special strap.

Contact your supplier or Ingersoll Rand for more information.

VTBH/V and SIAH/V Air Injection Blowers

Spare	Item Number
Oil-level sight-glass: SIAH/V blowers	C160340443
Oil-level sight-glass: VTBH/V blowers	C160210443
Mobilgear 630 Oil: 2 litres (0.53 US gal)	LUB0000002
Mobilgear 630 Oil: 5 litres (1.32 US gal)	LUB0000005
Winter/Summer Mobil SHC 630 oil: 2 litres (0.53 US gal)	LUB1000002
Winter/Summer Mobil SHC 630 oil: 5 litres (1.32 US gal)	LUB1000005
Discharge/injection manifold gaskets	
VTB810H/V	P152266916
VTB820H/V	P152126916
SIAH/V822	P162126916
SIAH/V840	P172266916
SIAH/V8072	P182266916
Filters (type F)	
90 m ³ h ⁻¹ (53 cfm) flow	A050210050
110 m ³ h ⁻¹ (65 cfm) flow	A050220040
200 m ³ h ⁻¹ (118 cfm) flow	A050230050
400 m ³ h ⁻¹ (236 cfm) flow	A050230065
550 m ³ h ⁻¹ (324 cfm) flow	A050230080
1100 m ³ h ⁻¹ (648 cfm) flow	A050230100
1500 m ³ h ⁻¹ (883 cfm) flow	A050230125
2500 m ³ h ⁻¹ (1472 cfm) flow	A050230150
3000 m ³ h ⁻¹ (1767 cfm) flow	A050230175
Cartridges (type F)	
3000 m ³ h ⁻¹ (1767 cfm) flow	A050230175
4000 m ³ h ⁻¹ (2356 cfm) flow	A050230200
6000 m ³ h ⁻¹ (3534 cfm) flow	A050230250
8000 m ³ h ⁻¹ (4712 cfm) flow	A050230300
10000 m ³ h ⁻¹ (5890 cfm) flow	A050230350
Cartridges (type C)	
475 m ³ h ⁻¹ (280 cfm) flow	A050910050
625 m ³ h ⁻¹ (368 cfm) flow	A050910065
580 m ³ h ⁻¹ (342 cfm) flow	A050910080
725 m ³ h ⁻¹ (427 cfm) flow	A050910100
1000 m ³ h ⁻¹ (589 cfm) flow	A050910125
2100 m ³ h ⁻¹ (1237 cfm) flow	A050910150
3200 m ³ h ⁻¹ (1885 cfm) flow	A050910175
4200 m ³ h ⁻¹ (2474 cfm) flow	A050910200
6000 m ³ h ⁻¹ (3534 cfm) flow	A050910250
8000 m ³ h ⁻¹ (4712 cfm) flow	A050910300
10000 m ³ h ⁻¹ (5890 cfm) flow	A050910350

Table 18 - Spares and accessories



ADDENDUM FOR INSTRUCTION MANUAL VTB 820 BRONZE

2.4 Lubrication data

Drive end cover > VTB 820H = 0.75 litres
 Drive end cover > VTB 820V = 0.45 litres
 Non drive end cover > VTB 820H = 0.80 litres
 Non drive end cover > VTB 820V = 0.39 litres

2.7 Material of construction

Rotors > Cu Sn 12-C-GS according to EN 1982

2.8 Items numbers

*** All the others data are the same like cast iron VTB

VTB 820 BRONZE ATEX cat.2					
Part list codes					
EA	Types machines	Shaft position	Rotation	Item number	Config *
			Direction		
135	VTB 820	Bottom	Anticlockwise	F1557201230	E
		Bottom	Clockwise	F1557201231	A
		Left	Anticlockwise	F1557201232	H
		Left	Clockwise	F1557201233	D
		Top	Anticlockwise	F1557201234	F
		Top	Clockwise	F1557201235	B
		Right	Anticlockwise	F1557201236	G
		Right	Clockwise	F1557201237	C
VTB 820 BRONZE STANDARD					
Part list codes					
EA	Types machines	Shaft position	Rotation	Item number	Config *
			Direction		
135	VTB 820	Bottom	Anticlockwise	F1557200042	E
		Bottom	Clockwise	F1557200040	A
		Left	Anticlockwise	F1557200046	H
		Left	Clockwise	F1557200045	D
		Top	Anticlockwise	F1557200044	F
		Top	Clockwise	F1557200043	B
		Right	Anticlockwise	F1557200048	G
		Right	Clockwise	F1557200047	C